



This is a digital copy of a book that was preserved for generations on library shelves before it was carefully scanned by Google as part of a project to make the world's books discoverable online.

It has survived long enough for the copyright to expire and the book to enter the public domain. A public domain book is one that was never subject to copyright or whose legal copyright term has expired. Whether a book is in the public domain may vary country to country. Public domain books are our gateways to the past, representing a wealth of history, culture and knowledge that's often difficult to discover.

Marks, notations and other marginalia present in the original volume will appear in this file - a reminder of this book's long journey from the publisher to a library and finally to you.

Usage guidelines

Google is proud to partner with libraries to digitize public domain materials and make them widely accessible. Public domain books belong to the public and we are merely their custodians. Nevertheless, this work is expensive, so in order to keep providing this resource, we have taken steps to prevent abuse by commercial parties, including placing technical restrictions on automated querying.

We also ask that you:

- + *Make non-commercial use of the files* We designed Google Book Search for use by individuals, and we request that you use these files for personal, non-commercial purposes.
- + *Refrain from automated querying* Do not send automated queries of any sort to Google's system: If you are conducting research on machine translation, optical character recognition or other areas where access to a large amount of text is helpful, please contact us. We encourage the use of public domain materials for these purposes and may be able to help.
- + *Maintain attribution* The Google "watermark" you see on each file is essential for informing people about this project and helping them find additional materials through Google Book Search. Please do not remove it.
- + *Keep it legal* Whatever your use, remember that you are responsible for ensuring that what you are doing is legal. Do not assume that just because we believe a book is in the public domain for users in the United States, that the work is also in the public domain for users in other countries. Whether a book is still in copyright varies from country to country, and we can't offer guidance on whether any specific use of any specific book is allowed. Please do not assume that a book's appearance in Google Book Search means it can be used in any manner anywhere in the world. Copyright infringement liability can be quite severe.

About Google Book Search

Google's mission is to organize the world's information and to make it universally accessible and useful. Google Book Search helps readers discover the world's books while helping authors and publishers reach new audiences. You can search through the full text of this book on the web at <http://books.google.com/>

WFD
G82
+

ARCHITECTURAL DRAFTING

A. BENTON GREENBERG
AND
CHARLES B. HOWE

WILEY TECHNICAL SERIES

Library
of the
University of Wisconsin









THE WILEY TECHNICAL SERIES
FOR
VOCATIONAL AND INDUSTRIAL SCHOOLS

EDITED BY
J. M. JAMESON
GIRARD COLLEGE

THE WILEY TECHNICAL SERIES

EDITED BY

J. M. JAMESON

TEXTBOOKS ON DRAFTING

By CHARLES B. HOWE, M.E., and Associated Specialists

Agricultural Drafting. By CHARLES B. HOWE, M.E., 4to, x+63 pages, 45 figures, XXVI plates. \$1.25 net.

Loose Leaf Manual in Agricultural Drafting. By CHARLES B. HOWE, M.E. Forty problem sheets to supplement the above text in Agricultural Drafting. Price two cents each.

Architectural Drafting. By A. BENTON GREENBERG, B.A., Formerly Inspector and Draftsman, Supervising Architect's Office, Washington, D.C.; Engineer and Inspector, Building Department, New York City; Practising Architect. In Collaboration with CHARLES B. HOWE, M.E. 4to, viii+110 pages, 53 figures, X plates. \$1.50 net.

IN PREPARATION

Mechanical Drafting

Engineering Drafting

Engineering Trade Drafting

The Loose Leaf Drafting Manual: Reference and Problem Sheets to supplement the texts in Drafting

For Full announcement, see page III.

ARCHITECTURAL DRAFTING

.BY

A. BENTON GREENBERG, B.A.

FORMERLY INSPECTOR AND DRAFTSMAN, SUPERVISING ARCHITECT'S OFFICE, WASHINGTON, D.C.;
ENGINEER AND INSPECTOR, BUILDING DEPARTMENT, NEW YORK CITY;
PRACTICING ARCHITECT

IN COLLABORATION WITH
CHARLES B. HOWE, M. E.

FIRST EDITION

FIRST THOUSAND

NEW YORK:

JOHN WILEY & SONS, INC.

LONDON: CHAPMAN & HALL, LIMITED

1913

Copyright, 1913,
BY
A. B. GREENBERG AND CHARLES B. HOWE

THE SCIENTIFIC PRESS
ROBERT DRUMMOND AND COMPANY
BROOKLYN, N. Y.

191443
JAN 26 1915
WFD
G 32

PREFACE

IN the preparation of this text on architectural drafting, the aim has been to present the cultural aspects of the subject as well as the practical; to instill a love for and an appreciation of all that is good and beautiful in architecture, as well as to lay a practical foundation for those to whom a knowledge of architectural drafting would be a vocational advantage. To comprehend the difficulties encountered by the architect in estimating the loads of a modern office building, in calculating and providing for the thrusts of a Gothic structure, or for the strains of a dome such as St. Peter's, leads to broader knowledge and to a deeper and more enlightened appreciation of good architecture. It is quite as essential in the training of an architectural draftsman that he should acquire a thorough knowledge of construction and an understanding of the principles involved, as it is that he should become expert in the operations of drafting.

The authors have departed from the usual plan of presenting a series of plates to be copied. Mere copying leads to superficial knowledge and mechanical skill, instead of promoting self-reliance and originality. The principles set forth in the text are illustrated by drawings representing types of construction and design. After a drawing is thoroughly understood, the student's knowledge of the principles involved is to be tested by requiring him to solve either a similar problem or one that is a step in advance. This method leads the student into a broader and freer way of thinking and working. He should be taught to observe closely, to understand fully, to digest thoroughly, and to apply what he has acquired with originality.

Model drawing plates as well as problem plates are presented on *loose-leaf sheets*, from which may be selected a *course of study* that is adapted to local needs. It is believed that this plan will enable those instructors who

prefer their own course of study, to use the text to advantage. Frequent additions will be made to the list of problem sheets and instructors are invited to correspond with the authors and to make suggestions freely.

The text has been adapted in its scope to the time

available for a course of one or two years in secondary schools.

The authors tender their acknowledgements to The National Fire Proofing Company, who have kindly loaned material for reproduction.

INTRODUCTION

IN arranging this text, an elementary knowledge, of mechanical and free-hand drawing on the part of the students, has been assumed. For this reason, no description is given of those instruments which ordinarily would be included in a rudimentary treatise in either subject. Special emphasis, however, is laid upon a description of such tools and materials as are used to a greater extent by architectural draftsmen than by those in allied trades and professions.

The ability to sketch rapidly is of inestimable importance to the mechanic as well as to the architect. During the erection of a building, problems in construction are constantly arising. The foreman and superintendent may have occasion to discuss some detail of construction. In such discussions, sketches, rough but accurate, are frequently of the greatest assistance. These sketches are made on any available part of the structure. Should the architect appear upon the premises, the question is presented

to him. He either approves a plan already discussed or suggests, also with sketches, an entirely new solution. Enter any house in course of construction and you will find on the unfinished plastered walls or sheathing rough sketches, reminders of just such discussions. The student, therefore, should be given practice in quick, freehand drawing. He should be able to supplement his statements with sketches. This may be accomplished by requiring him to render freehand all solutions to the problems given, either on cross-section paper, or, better still, in note books. The teacher should also illustrate his talks with quick sketches, that the student may have constant training in reading and interpreting drawings.

All building operations are regulated by local laws or ordinances. The authors have adopted the New York City Building Code for this text as well as for all plates, not only because the requirements are ample and always on the side of safety but also because they form the basis

of practically all other building regulations. It has been deemed expedient to dwell at greater length upon frame buildings than upon those constructed of brick, concrete, or steel, because the former are more easily

comprehended, require a minimum of static computations, and have many details, particularly of interiors, in common with all classes of buildings, masonry or otherwise.

CONTENTS

| | |
|--|------|
| SECTION I | |
| DRAFTING IMPLEMENTS | |
| | PAGE |
| Architectural versus mechanical and freehand drawing—Instruments—Drafting materials; scales, pencils, rendering outfit, tracing paper, tracing cloth, Whatman paper—“Stretching” | 1 |
| SECTION II | |
| THEORY AND PRACTICE OF DRAFTING | |
| Definitions; plans, sections, elevations, details, specifications—Technique of expression—Conventions; materials, plans—Principles of expression—Design | 8 |
| SECTION III | |
| MATERIALS OF CONSTRUCTION | |
| Brickwork; manufacture, classification, joints, bonding, terms—Stonework; kinds—Masonry walls; varieties, joints—Cement; kinds—Mortar; kinds—Concrete; plain and reinforced—Terra- | |

| | |
|---|------|
| | PAGE |
| cotta; ornamental and structural—Blocks; concrete and terra-cotta | 22 |

| | |
|--|----|
| SECTION IV | |
| BUILDING CONSTRUCTION | |
| <i>A. Masonry</i> | |
| Selection of site—Arrangement of rooms—Water-proofing—Excavation—Footings—Walls; kinds, thickness—Brick construction—Stone masonry construction—Concrete construction; laying, forms—Different methods of reinforced concrete, concrete block and terra-cotta construction | 31 |

| | |
|---|----|
| SECTION V | |
| BUILDING CONSTRUCTION | |
| <i>B. Frame</i> | |
| Frame construction; braced, balloon and combination—Partitions—Chimneys—Roofs; finish, types—Wall covering; siding, clapboard and shingles—Stucco—Windows—Doors—Interior trim—Plastering—Stairs; terms, classification, layout, construction. | 45 |

| SECTION VI | | PAGE |
|--|------|------|
| DESIGN | | |
| | PAGE | |
| Architecture defined; utility, beauty—Factors in design; expression, proportion, fenestration, decoration—Style—Structure principles; pier, lintel, arch, truss. | 69 | |
| APPENDIX I | | |
| SPECIFICATIONS | | |
| Object—Scope—Order—Index—General conditions and sub-headings—Mason's specifications—Carpenter's specifications— | | |
| Plumbing specifications — Electrical specifications — Heating specifications; and sub-headings under each trade. | | 75 |
| APPENDIX II | | |
| ESTIMATING | | |
| Cost of labor and material—Estimates; kinds—Approximate estimates; methods—Detailed estimating—Arrangement of estimating sheet—How to estimate:—Excavations—Masonry; stonework; brickwork; plastering—Carpentry—Roofing—Plumbing—Piping and wiring—Heating—Hardware—Painting—and papering—Summary—Estimating data and tables | | 88 |

ARCHITECTURAL DRAFTING

SECTION I

DRAFTING IMPLEMENTS

1. Architectural versus Mechanical Drawing. Architectural drawing is characterized by a freedom and "snap" totally alien to mechanical drawing. The latter must be absolutely exact, rigid, and drawn with a very hard pencil. Once having decided upon the shape of a piece of machinery, it must be worked up with a precision which admits of little originality in the design of its constituent elements. They must all be of a definite size and form, one part fitting into the other with a mathematical exactness. No such limitations hamper the architectural draftsman. However definite the problem in hand, he may exercise his originality in any number of ways. The designer has before him the entire field of architectural styles from which to choose: The Egyptian, the Greek, the Roman, the Renaissance, the Gothic or the Art

Nouveau. One style may appropriately be selected or a judicious combination effected; but even if the style or external adornment of the building has been decided for him, the draftsman can still show his initiative in the height of the rooms, in the proportion of the openings, in the color schemes of the exterior and the interior, in the construction, and in numerous other ways.

2. Architecture a Science. We have remarked upon the mathematical accuracy of mechanical drawing. The impression, however, must not prevail that architecture is inexact. *Architecture is a science as well as an art* and as such must be exact; but it is an exactness that admits of some freedom, provided of course, that it is exercised on the side of safety. To illustrate: The building laws of particular localities prescribe definite loads which every

member of a structure must be capable of sustaining. Absolute accuracy must therefore obtain in the calculation of beams, girders and their supports; in the thickness of walls, etc. A larger factor of safety, however, may be assumed, which will necessitate an increase in the size and weight of the various members, with no detriment either to its stability or its design.

3. Architectural versus Free-hand Drawing. Architectural drawing combines the principles of both mechanical and free-hand drawing. The draftsman in the preliminary stages of a problem uses a soft pencil with which he does a considerable amount of sketching. In the gradual development of the design, he makes less use of freehand and more of mechanical drawing; in no stage of the work, however, entirely abandoning either.

The mechanical element in architectural drawing aids in the development of manual dexterity, while sketching assists in the training of observation and memory.

4. Tools and Materials. In view of the close relation between architectural, free-hand, and mechanical drawing, referred to in the preceding paragraphs, the student of architecture should provide himself not only with the tools and instruments of the mechanical draftsman but also with such other accessories as will aid him in making quick sketches; such as soft pencil, soft eraser and tracing paper.

5. Instruments. Little need be said of the variety, care and use of instruments, for one can find such information in any standard work on mechanical drawing. We shall therefore dismiss the subject with only a word as to *the quality* of tools. Procure the best instruments, as with reasonable care, they can be made to last a lifetime. The ordinary drafting outfit is shown on Plate I.

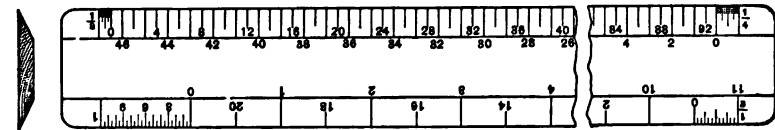

FIG. 1.—Flat Scale.
Graduated $\frac{1}{8}$, $\frac{1}{4}$, $\frac{1}{2}$ and 1 inch to the foot.

6. Scales. There are two types of scales: *flat* and *triangular*. The latter has more graduations than the former but the difficulty in handling the triangular scale

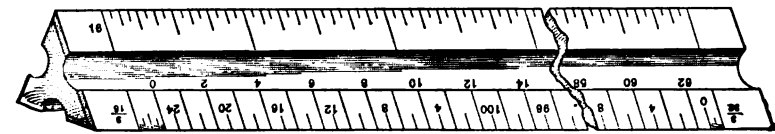
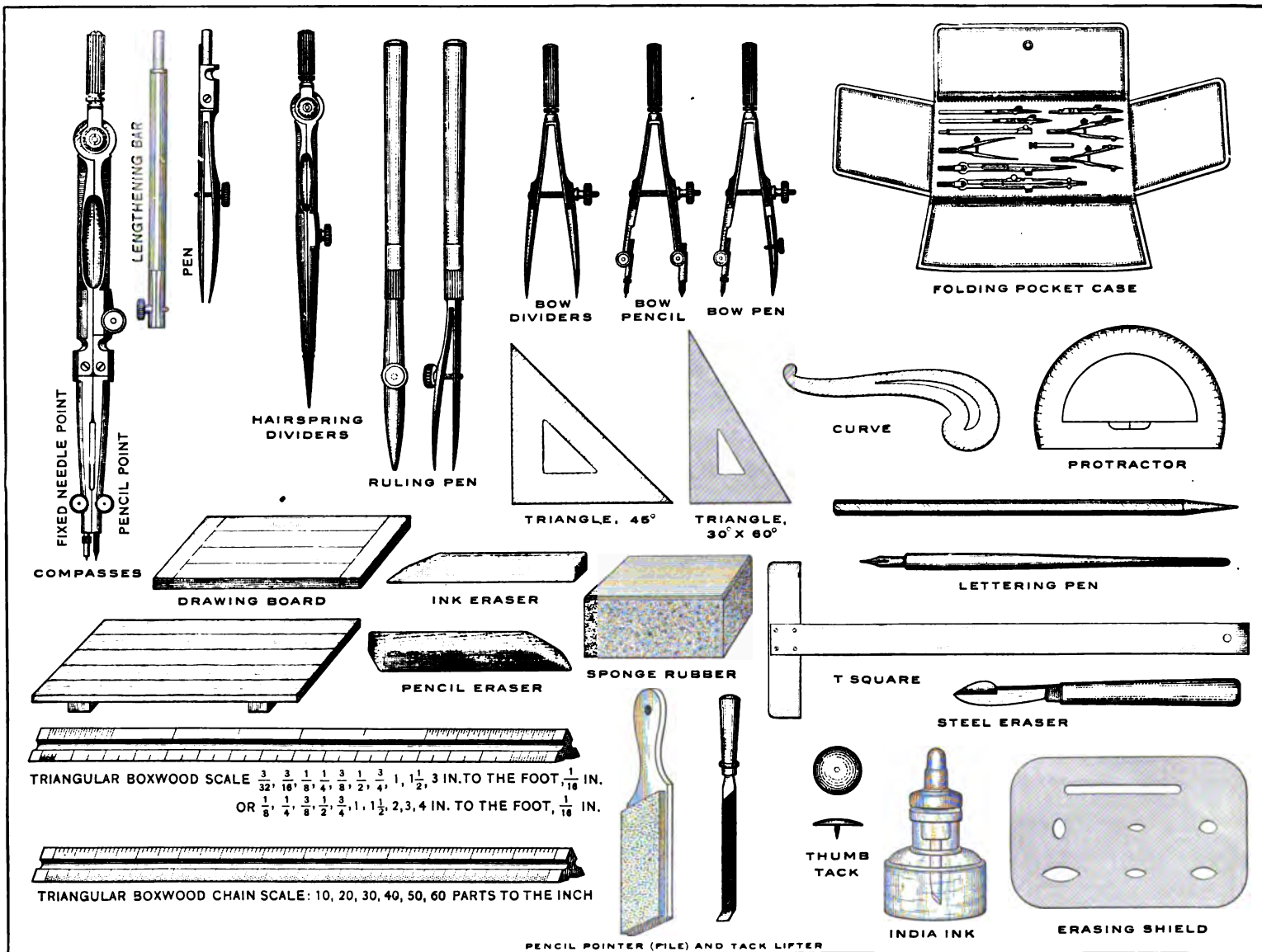

FIG. 2.—Triangular Scale.
Graduated $\frac{1}{8}$, $\frac{1}{4}$, $\frac{1}{2}$, $\frac{3}{4}$, 1 , $1\frac{1}{2}$, 3 inches to the foot, and on one edge, inches and 16ths.

and the time lost in finding the required division added to its greater cost, render it less practical than the flat scale. Both varieties are illustrated in Figs. 1 and 2.



7. Drawing to Scale. A drawing that is made to scale is a representation of an object either in its full size or with all its dimensions proportionately reduced. Very rare indeed is the case in architectural drawing when anything is represented greater than full size. The scale of "one eighth of an inch equals one foot" means that every one eighth of an inch on the drawing represents one foot in the finished structure. Three-quarter inch, one inch, one inch and a half, and three inch scales are most frequently used for special drawings to illustrate clearly the important units in a design, typical details, or some unusual point in construction. As a rule, capitals, bases, entablatures, decorations, stairs, sections of moldings, fireplaces, and mantels are drawn to the large scales. Working drawings are made to a scale of $\frac{1}{4}$ inch to the foot, while preliminary sketches are laid out at $\frac{1}{16}$ inch or $\frac{1}{8}$ inch to the foot, depending upon the size of the building.

The scale to which a drawing is made is generally placed in the lower right-hand corner of the sheet and may be stated either in figures, thus:

$$\frac{1}{8}'' = 1' - 0''; \quad \frac{1}{4} \text{ inch} = 1 \text{ foot};$$

or graphically, thus:



8. Pencils. Pencils of a superior quality only should be used. Chief among the characteristics of standard pencils are correct and uniform grading, resistance to wear, and the absence of grit in the graphite. For sketching, a soft pencil designated in the trade by the letter *B* is appropriate; a *2B* pencil may also be used. If a softer grade is employed, the drawing is liable to become soiled. Suitable pencils for preliminary work are *F* and *HB*; for finished drawings, *H* and *2H*. A pencil harder than *2H* will indent the paper and make erasures difficult.

9. Equipment for Rendering. All academic problems and exhibition drawings are *rendered* either in India ink



FIG. 3.—Ink Slab.

or water-color. The student should therefore procure a box of water-colors and three good brushes; two of camel's hair and one of sable. He should also provide himself with a slate ink slab, similar to the one illustrated in Fig. 3. Into this receptacle a little water should be poured and a stick of ink (Fig. 4) rubbed, with a rotary

motion, over the ground edges of the slab. The result will be a uniform mixture admirably suited for washes and fine line work. A nest of porcelain saucers or a pallet slab, as shown in Figs. 5 and 6, completes the outfit.



FIG. 4.
Sticks of India or Chinese Ink.



FIG. 5.—Nest of Cabinet Saucers.



FIG. 6.
Ink and Color Slab.

10. Tracing Paper. Tracing paper should be used unsparingly in the preliminary studies of a project. Every new idea that enters the mind of the draftsman should be jotted down, studied and worked up. The first sketch, being the initial effort in the interpretation of a problem, can almost invariably be improved upon by further consideration of its program. Subsequent alterations may be made by simply placing tracing paper over the previous

efforts, tracing those parts which require no change and then making the necessary additions and substitutions. Besides the economy wrought in the laying out of the work, tracing paper is valuable in that at the end we have for comparison, in a very convenient and well preserved form, all possible solutions of the problem. The better grade of tracing paper may be used for finished working drawings and prints may be taken directly from it. If stretched, that is, if its edges are glued to a board and the entire surface slightly moistened with a sponge and allowed to dry taut, it will take water-colors without shrinking or buckling. It may then be effectively mounted.

11. Tracing Cloth. For more important work the final drawings should be made on tracing cloth. Many prints may then be taken, more vigorous erasures made, and the drawing may otherwise be subjected to greater wear and tear. The dull side should be used for pencil or brush work in preference to the smooth; either side may be used for ink. To insure the ready flow of ink, chalk dust or specially prepared powder should be sprinkled over the surface and then rubbed vigorously with a piece of flannel. All particles of dust or powder must be removed before inking.

12. Whatman's Drawing Papers. Whatman's paper possesses an elasticity and durability of surface that make it peculiarly adapted to ink and wash drawings.

For pencil, ink, and very fine line work, a grade known as Whatman's "Hot Pressed" paper is used. It has a smooth surface. Whatman's "Cold Pressed" paper has a finely grained surface and is suitable for water-color painting.

13. Stretching. If the paper is "stretched," it will take water-color without shrinking or buckling. A stretch is made by bending up the edges of the paper one inch all around, very carefully, so that there are no creases. The paper is then moistened thoroughly with a soft sponge, applied gently over its surface. No water should be allowed to remain in pools or be permitted to run over the edges. The paper is now ready for the glue or paste, which should be generously applied to the underside of the folded edges. To insure a perfect adhesion, the paper should be stretched toward you while the edges are being pressed down with the fingers of both hands. Start this operation at the midpoint of the edge of the sheet, working

simultaneously toward the right and left; continue in this way on the other edges. The paste is then squeezed out with the back of a knife or other hard object. Occasionally the knife is rubbed vigorously over the edges to secure a better adhesion. In the meantime the paper should be kept thoroughly wet. Then remove the surplus water with a clean sponge, place the board in a horizontal position, far removed from any kind of heating apparatus, and allow it to remain in this position until the paper is dry and stretched taut.

14. Manila Paper. Manila paper of a medium weight is always used for full-size drawings. These are generally executed with a soft pencil and are prepared while the building is in course of construction. Manila paper comes in rolls of one hundred yards each and is from thirty-six to fifty-four inches in width. It takes India ink and crayon well but can stand only a moderate number of erasures.

SECTION II

THEORY AND PRACTICE OF DRAFTING

15. Methods. Architectural drafting may be studied by either the *analytic* or the *synthetic* method. In the latter, the order of procedure is first to draw a structure in its entirety and then to make a study of its details. For the synthetic method it is claimed that the student follows the same course he would pursue in an office and that he works with a clearer understanding than he would if he had to draw a number of miscellaneous, unrelated parts of a building. On the other hand, the adherents of the analytic method contend that the most uncouth and impracticable designs are made by students who know nothing of the construction of the various recurring elements of a structure, such as doors, windows, roofs, etc.

16. Synthetic-analytic Method. A happy medium may be found by combining the good points of each system in the *synthetic-analytic method*. The student should constantly refer to a complete set of plans as he draws details. A building, it should be remembered, is an aggregation of connected units; system and coherency must therefore prevail in its representation. The foundation

should be considered first; then the superimposed walls, the crowning roof, the exterior finish, and finally, the interior embellishments should follow in consecutive order. These elements should be carefully studied by themselves and in relation to one another. The plans should be consulted for width of openings; elevations and sections for height of openings. Studied in this manner, the beginner soon acquires a proper conception of the elements when represented conventionally. Knowing them and their conventional representation, it will not be difficult for the student to combine them in original designs.

17. Plans. A plan is a horizontal section taken through a building at such a height above the floor as will show to best advantage the arrangement and construction. See Plate II. A plan reveals the outline of exterior walls and their thickness, the arrangement of rooms, means of communication, positions of all openings, fixtures and other appurtenances.

“Plans” include not only the plans of the various floors but also all elevations, sections, and details. It is

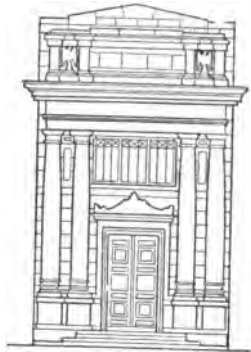

(a) Elevation.

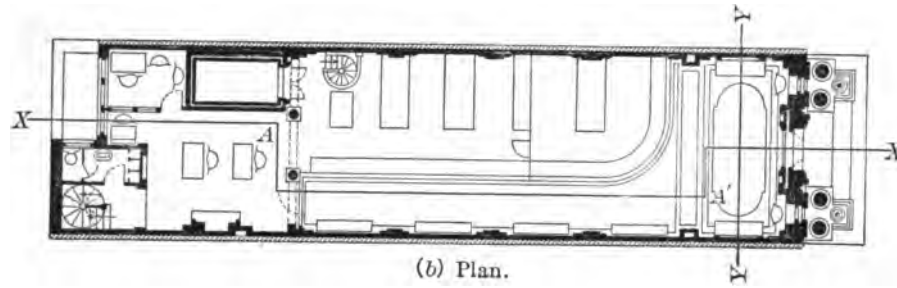

(b) Plan.

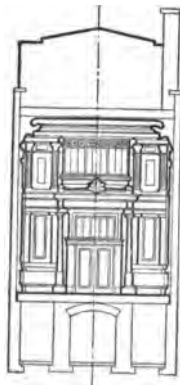

(c) Transverse Section on Line Y-Y.

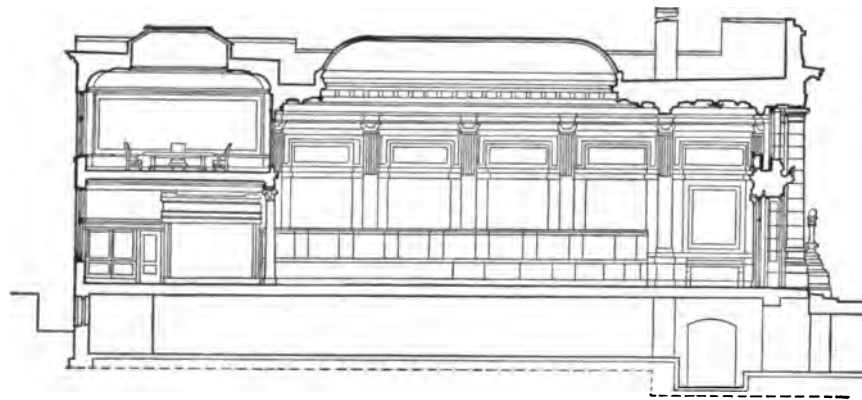

(d) Longitudinal Section on Line X-X.

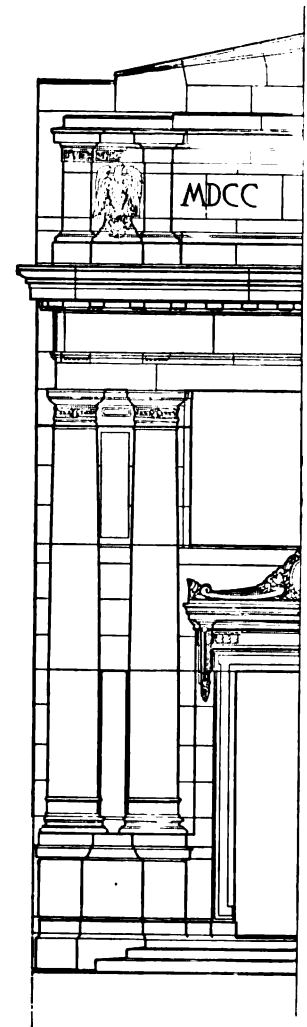

(e) Detail of Facade.

a term applied to any set of drawings necessary to give a builder a clear understanding of the completed structure.

The most important drawing is the ground floor plan, for it determines in a great measure the arrangement of the rooms of all the other floors and consequently fixes the character of the elevations.

18. Sections. A section is the view obtained by cutting through a building vertically. Its purpose is to show the construction, arrangement and architectural treatment of the interior of a structure. If a building is cut through its center crosswise and vertically, the resulting section is known as *transverse*; see Plate II. A *longitudinal* section as illustrated in (d), is obtained if the building is cut through lengthwise and vertically. A section is marked by the same letters that identify the traces of the cutting plane on the plan. The section plane may be discontinuous, that is, carried in a zig-zag course through different rooms, if by so doing more information may be obtained. To illustrate: the trace of the section plane X-X if continued in a straight line would not show the design of the screen. Therefore, the section line is broken at A. It is again broken at A', for, if continued in a straight line, it would pass through a solid wall. By changing its direction to pass through the main entrance, a maximum amount of information is given.

19. Elevation. An elevation is a vertical projection of the exterior of a building or part thereof; see Plate II. It reveals the style of architecture employed, the height between floors, the size and position of the openings and the kind and dimensions of the materials. The front elevation of a building is sometimes referred to as its *façade*.

20. Details. Details are enlarged scale drawings of parts of a structure; see Plate II. They are used to elucidate those decorative and constructive features which cannot be shown with sufficient clearness and accuracy on small scale drawings. Detail drawings are either made full size or to a scale large enough to make them intelligible to the mechanic. The most common scales used for this purpose as well as those parts usually rendered to an enlarged scale are enumerated in Section I, paragraph 7.

21. Specifications. The specifications contain a clear and concise description of all the materials entering into the construction of a building, their quality and the character of workmanship required in their erection. This subject is presented in detail in Appendix I.

22. How to Approach a Problem. Plan and elevation should be worked up simultaneously. The exterior and interior of a building should be conceived as a unit. The disadvantage of completing one to the exclusion of the other becomes apparent when one considers their recip-

rocal relations and interdependence. A design may present a beautiful appearance, with its well proportioned and properly distributed window openings, with its wide belt courses and its imposing columns and pilasters; but when the plan is drawn, and all the parts placed as indicated on the elevations, a partition may be found to come directly in the center of one of the windows, or, wide belt courses may be impossible or columns not feasible, because they shut out too much light. Similar incongruities will result if the plan only is considered. Openings in the walls of a plan, when transferred to the elevation, may show an exterior ill-proportioned and lacking in balance, symmetry and unity.

23. Starting Point in Design. A building should be designed from within, outward; or in the language of L. E. Sullivan, "*Form should follow function.*" Start with the organic character of the building, then give a charming but proper expression to its function. Consideration should be given first to the plan or layout of the structure, always keeping in mind its purpose, the convenience and health of its occupants, and the strength and appropriateness of the materials that enter into its construction. For every line of the plan drawn there should be a mental image of the elevation of that line. The student should learn to visualize. He must so train his imagination that he can mentally construct the appearance of the

edifice from the plan without resorting to paper and pencil. Occasionally it proves helpful to make "thumbnail" sketches, that is, small free-hand drawings of the various elevations of the building.

24. Procedure. Whether it is the student working on a theoretical problem or the architect meeting a practical issue, the *method of procedure* is the same. The first thing the architect does is to familiarize himself thoroughly with the conditions or program. This he accomplishes by means of a series of **sketches** drawn to no definite scale; the problem is attacked from every possible angle. He experiments with the conditions, analyzing them, combining them, and testing them, until he finally reaches a tentative solution in harmony with his standards of architectural excellence and with the least expenditure of economic units.

Thus far no T square, triangle or other mechanical drawing tool has been used. However, once having decided upon a scheme which to the designer appears to be the best possible solution of the problem, he brings to his aid his tools and instruments and attacks the problem mechanically. The draftsman makes drawings of the tentative solution to $\frac{1}{8}$ -inch scale. In large work $\frac{1}{4}$ -inch, or even $\frac{3}{8}$ -inch scale is used. The walls in these drawings are in *poché*, that is, shown black. This is done for the purpose of setting the walls off in relief, thereby making them

more vivid and easier to trace. About half a dozen solutions of the project,—generally referred to as **preliminary drawings**,—consisting of plans, elevations and probably one or two perspectives, are drawn on tracing paper and shown to the owner. The strong and weak points in each study are pointed out and discussed. The scheme selected is now redrawn, embodying the suggestions made by all interested parties. The finished sketch is again submitted to the owner and if it meets with his approval **working drawings** are made to a scale of $\frac{1}{4}$ " to the foot and the specifications are written.

25. Contracts. One complete set of plans and specifications is sent to each of several contractors and bids are invited. The lowest bidder is usually awarded the contract. If the estimates are too high, the plans and specifications may be modified and new bids invited, or, if the owner is capable of doing the superintending himself, the work may be let in sections, separate bids being received from the carpenter, the mason, the plumber, etc.

If the architect superintends the job, he inspects the work during its progress, at irregular intervals, to ascertain if it is being built in accordance with the plans and specifications. As superintendent, the architect has the authority to reject inferior materials and to order the removal and reconstruction of defective work. There are two methods of making payments: first, when the work

is completed and approved by the architect, and, second, when a section of the work is finished and approved.

26. Technique of Expression. All lines should be made of an even tone, firm, clean and distinct. *To give a drawing character* the silhouette or outline is made heavier than the rest; see Plate III.

Sometimes the texture of the line is changed to distinguish surfaces in shadow from those in high light, or to differentiate parts of a building, or units in a group of buildings in the foreground from those in the background.

Lines are not made heavy at the outset; they are all drawn uniformly light at first and then those are accented which tend to give the building prominence, and help to infuse life and vigor into the drawing. Lines intended to meet at an angle are permitted to extend beyond the point of intersection. This practice should not be carried to excess; the lines should never project more than $\frac{1}{32}$ of an inch.

The profiles of all curved moldings, particularly in drawings to one eighth inch and one quarter inch scales, may be made free-hand to good effect. All these practices tend to take away from architectural drawing the stiffness and severity which are characteristic of mechanical delineations.

27. Order of Inking. In general, lines are drawn from left to right, and from the bottom up. The exterior walls

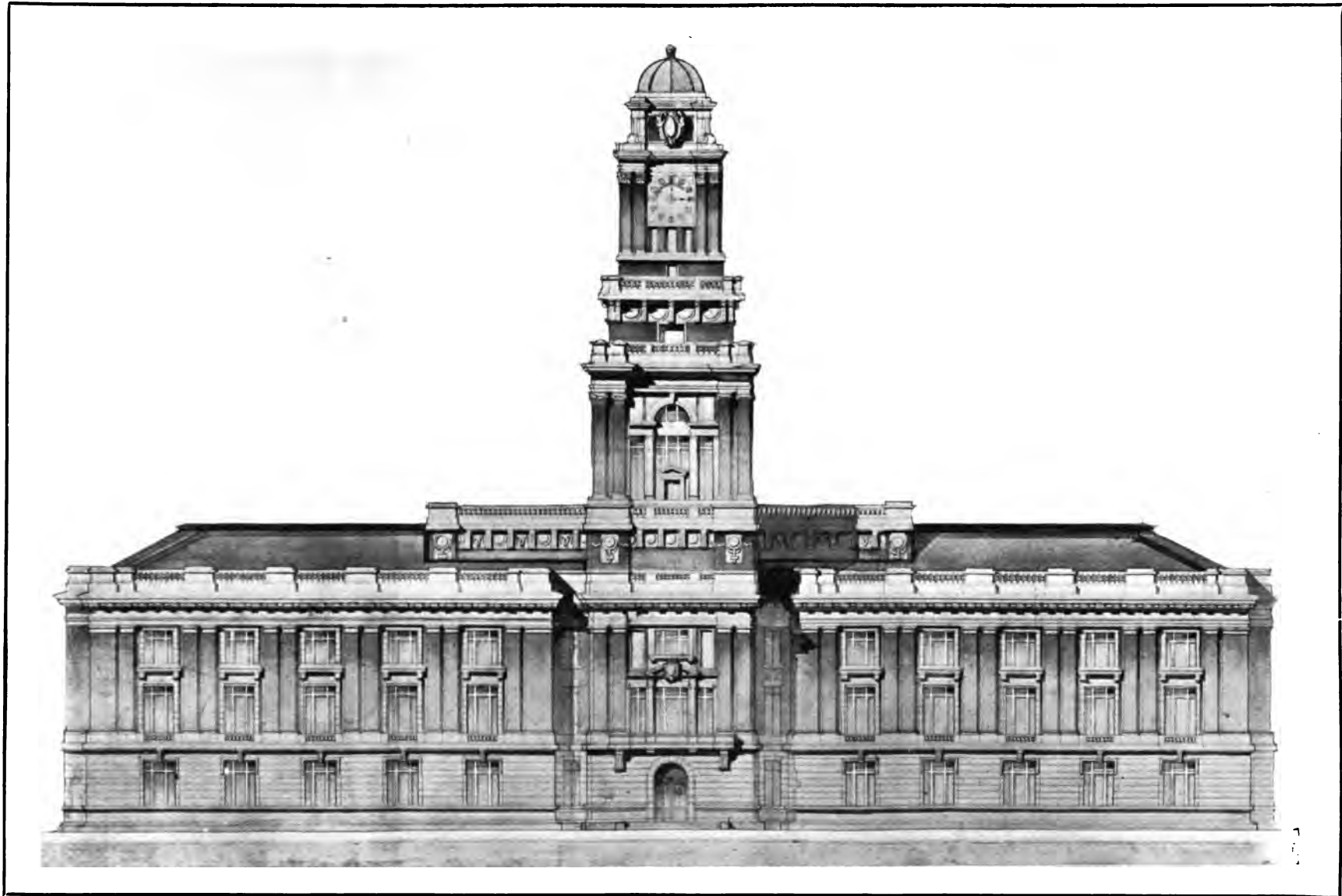

or limiting lines of a building are drawn first; the interior arrangement, fixtures, dimension lines, dimensions, notes, title and border line, follow in the order given. A drawing should be completely finished in pencil before it is inked. In transferring a drawing to tracing cloth, first ink arcs of circles and irregular curves; then draw all horizontal lines, commencing at the top and working down. All circles or arcs which can be described with the same radius should be completed before the compass is reset for a larger or smaller circle. All lines that can be drawn while the T square or triangle are in one position should be finished before either the T square or triangle is shifted.

28. Dimensioning. Dimension lines should be made with red or diluted black ink, so that when reproduced they will appear as fine, faint lines easily distinguishable from the full lines of the drawing. The arrow heads at the extremities of the dimension lines are made with black ink to bring them out clearly when blue printed, showing plainly from what point to what point the measurement is taken. All dimensions over one foot should have both feet and inches expressed, even though the dimension may be in even feet; for example, five feet would be represented thus: 5'-0'' and not 5'. This precaution is taken to prevent the complications which so frequently arise from mistakes, or from inadvertently writing the sign for feet (') for that of inches ("). If a dimension is

in feet and a fraction of an inch, it should be indicated thus: 5'-0 $\frac{1}{2}$ ''.

All dimensions must be carefully figured and checked to insure that each over-all dimension is equal to the sum of all its components; thus, in Fig. 7, all the dimensions in each of the lines *B* and *C* should be scaled and checked to see that the total is 34'-6''.

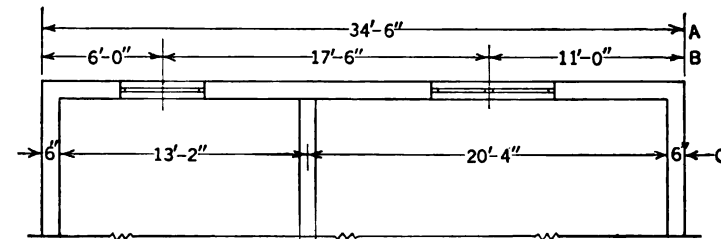
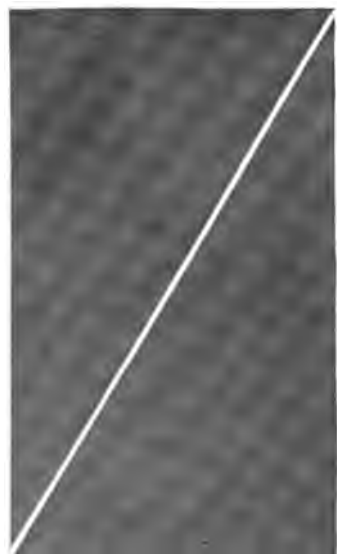

FIG. 7.—Dimensioning.

29. Rendering. Satisfactory results in laying washes of color can be attained only by constant practice. However, a few suggestions may be given that will be of assistance to the beginner. Color of the required tint should be mixed in sufficient quantity to cover the entire surface to be rendered. Tilt the board slightly; when laying the wash, carry it down with a brush well filled with the tint. Unless there is a liberal pool of the liquid at every step of the operation there is danger of the wash drying and forming lines or streaks.

METHODS OF RENDERING.

PLATE IV.



30. Washes. There are two kinds of washes—*flat* and *graded*. Flat washes may be applied in the manner described in the foregoing paragraph. In laying graded washes three methods are available, as follows: First, work a given distance with the darkest tint; add a little water, stir well, and carry the mixture down the same distance as the first wash. Proceed in this manner until the entire surface is covered. This method may be reversed by starting with a very light tint and gradually adding more color as the work progresses. Second, have several saucers each containing tints of different strength. Beginning with the lightest or the darkest, apply the graded tint successively for equal distances. Third, lay successive flat washes over a gradually contracting area. This is accomplished by marking off the surface to be rendered into a number of equal divisions, say six. Lay a very light wash over the entire six divisions. When this is thoroughly dry lay the next wash over all except division one. This is followed by a wash covering all but divisions one and two. Proceed in this manner until the coats are all applied and, when completed, division six will have received six coats, division five, five coats, etc. The various methods of rendering are illustrated in Plate IV.

31. Architectural Symbols. (a) *Materials.* Building materials are frequently represented by "conventions" or "symbols" as shown in Plate V.

The conventions illustrated are not arbitrary, although they conform to the best office practice. Owing to the non-standardization of architectural symbols, there is diversity in their representation. For that reason every set of plans has or should have an index or key to the various conventions employed. This may take the form of a drawing in which are small rectangles filled with sections of the materials used (Fig. 8), or of notes con-

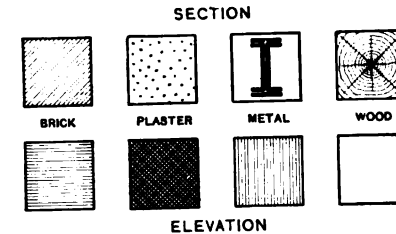
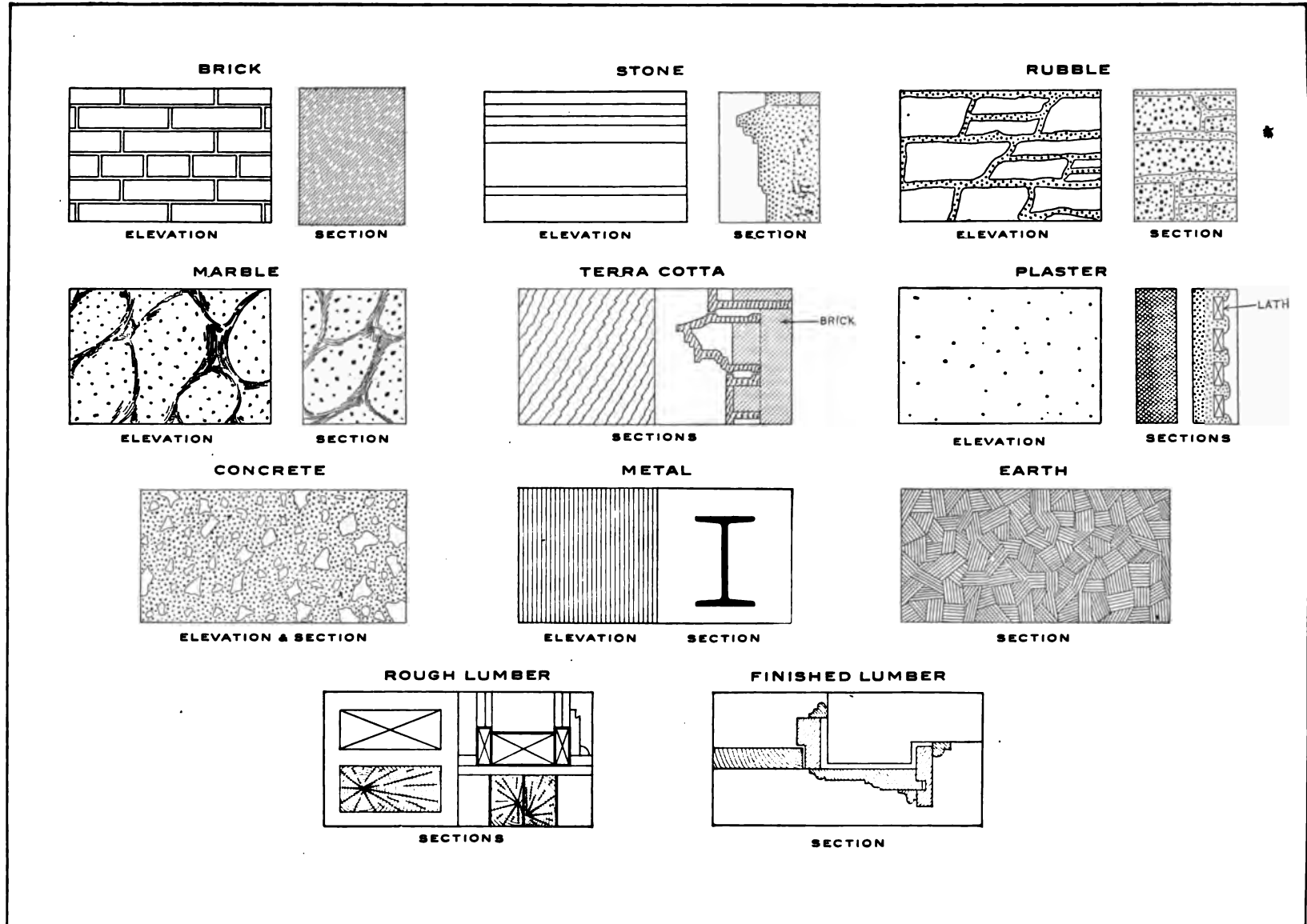

FIG. 8.—Key to Materials.

veniently placed in the drawing, as shown in Fig. 9. A third way of indicating materials is by the use of colors, as follows:

- Red, light or Venetian—brick.
- Prussian blue—plaster.
- Green—terra-cotta.
- Sepia—stone.
- Indigo blue—iron.
- Burnt umber—earth.
- Raw sienna or ochre—wood.
- Sepia, speckled with India ink—concrete.



(b) *Building Details.* Architectural drawing is necessarily of a conventional character. Working drawings are made at a scale so small that accurate representation is impossible. It is necessary for the draftsman,

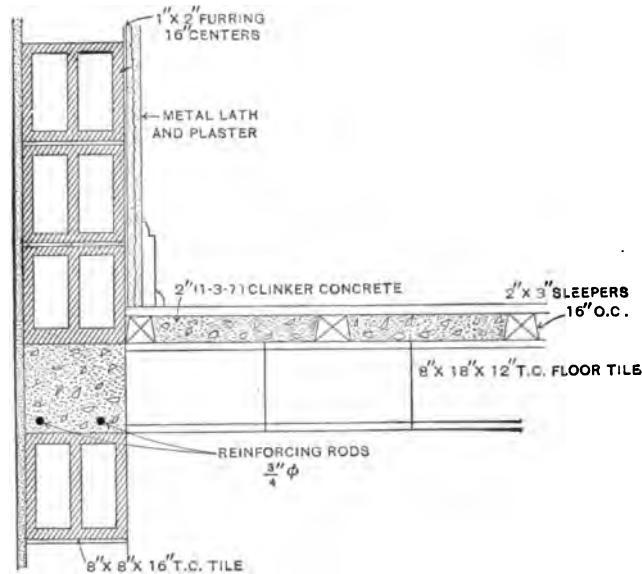

FIG. 9.—Method of Indicating Materials.

therefore, to employ such conventions as are in common use. A code of symbols conforming to good office practice is given on Plate VI.

32. Working Drawings. Architectural drawings may be classified under one of two headings: working drawings and exhibition drawings. The *working drawing* is

solely for the use of the contractor. The original is sometimes made on tracing paper but more often is inked on tracing cloth. This is invariably retained by the architect as a matter of record and for future reference. The builder always works from a blue-print of the original. Paradoxical as it may seem, a working drawing contains a minimum of lines and a maximum of information. If a façade is symmetrical about a vertical axis, only one half of it is drawn; very often half a section and half an elevation are combined. If the arrangement of rooms on two or more floors are the same, the plan of only one floor is drawn and the similarity of the other floors noted on the plan. If tiles are used as a roof covering, only two or three tiles are drawn accompanied with a note describing, in as few words as possible, the kind and manufacture of tile desired for the entire roof. In short, a working drawing must not only be exact but it must be concise.

33. Exhibition Drawings. An *exhibition drawing*, on the other hand, is elaborated and made picturesque. No lines are omitted and no artifices neglected that will aid in giving a drawing life, interest and beauty. It is made for the benefit of the layman, the owner, or the committee who cannot interpret working drawings. Exhibition drawings are made on Whatman's paper and are usually water-colored. The plans contain no measurements; walls

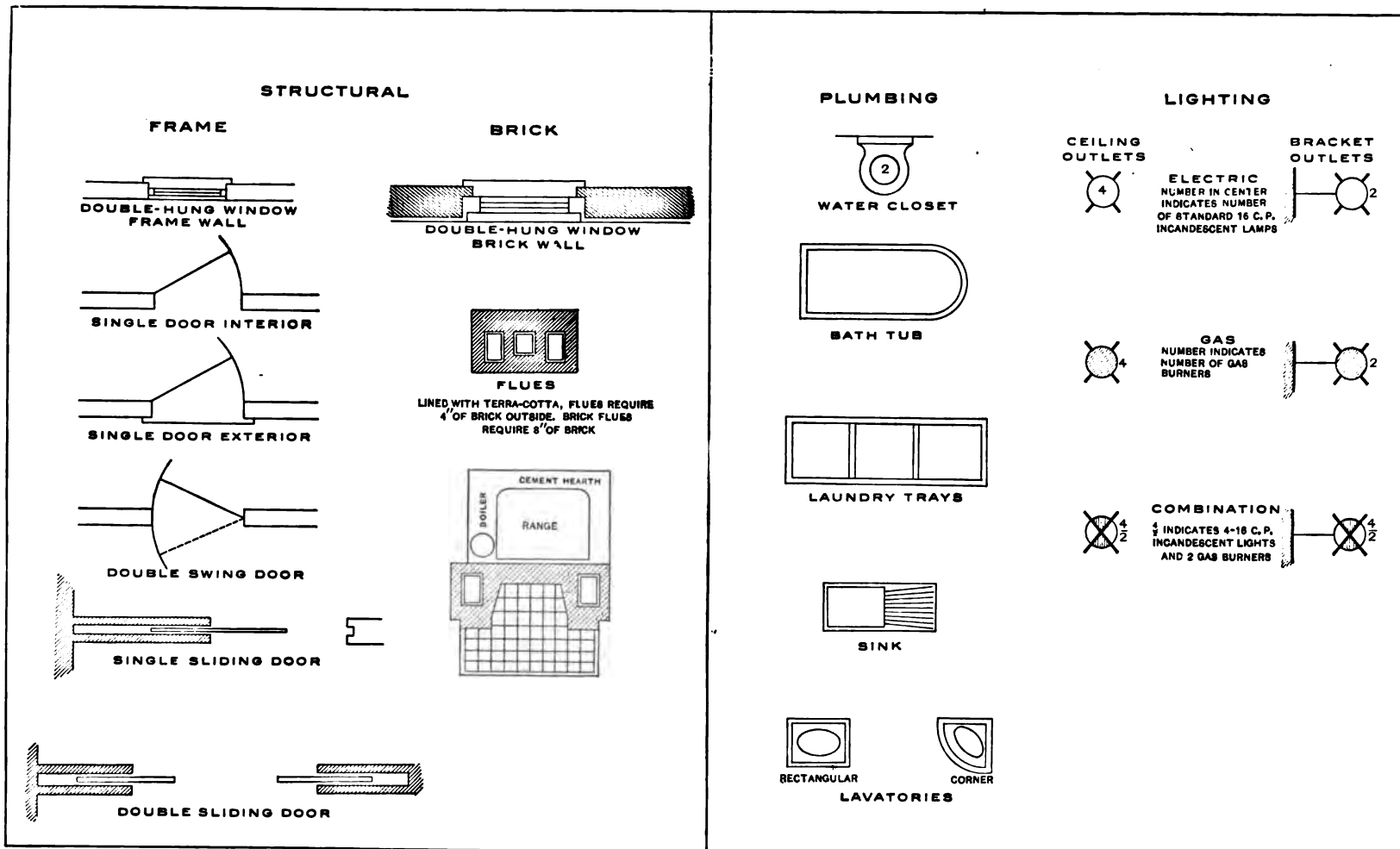

and partitions are in *poché*; in the elevation shadows are cast and a background of trees and sky provided. Every device is resorted to that will give an appearance of reality to the structure. Not infrequently a perspective of the projected building is made. In fact so great has become the demand for this class of drawings that there are many artists and architects who make a specialty of architectural perspectives. It is sometimes very difficult to distinguish a perspective made by one of these specialists from an actual photograph of the completed edifice.

34. Principles of Expression. (a) *Axes.* The imaginary lines upon which and around which the plan is built, are called *axes*. The main axis should pass through the center of the mass and should result in a well balanced and *symmetrical arrangement* of dominant parts. There are also auxiliary axes for the minor features of the plan. For example in Fig. 10, note the symmetrical disposition of the elements of the plan on either side of the axial line A-A; note also how the minor axis B-B is offset by C-C, etc. Now let us examine a room, such as D and see how the law of balance applies. In the center of the further wall is a chimney; and on either side a door and wall space are symmetrically arranged; the openings in the side walls balance each other; and the windows in front are uniformly disposed. Furthermore, a line drawn

through the centers of these windows will pass through the center of the doors and fireplace in the wall opposite.

(b) *Balance.* From the foregoing study it may be seen

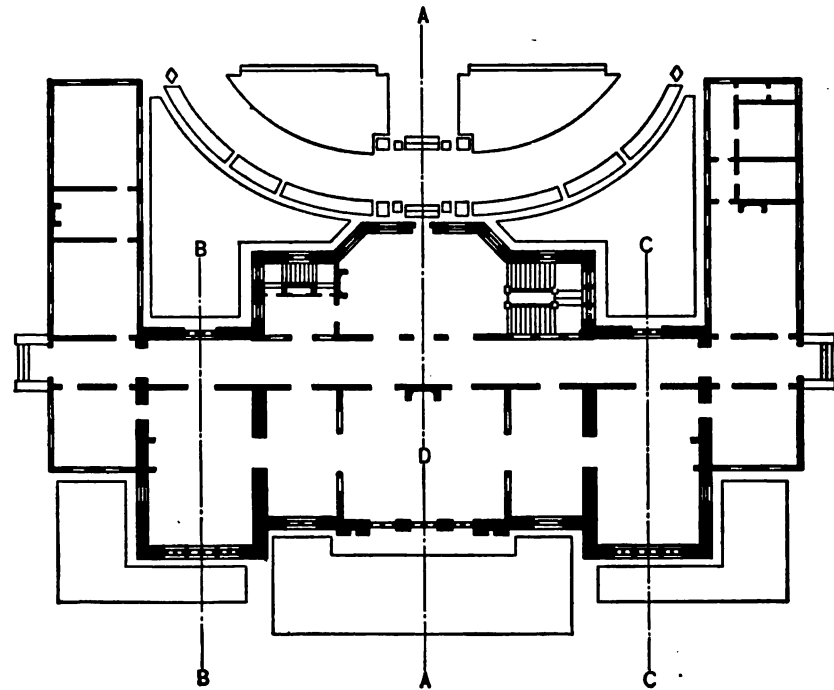

FIG. 10.—Axes.

that *balance* should obtain in the massing of the main divisions of a plan or an elevation, separately as well as collectively, to the end that unity may be wrought in the

design. On the other hand a strained endeavor to secure symmetry may result in a composition which is inartistic, for symmetry, it must be remembered, is not balance. One must trust to experience to obtain balance in an unsymmetrical design. However, the beginner should strive for symmetry, for then the possibilities of producing a poor design will be considerably lessened. The simplest way of recognizing the law of balance in architecture is to dispose symmetrically the elements of plan and elevation on either side of axial lines.

(c) *Unity*. Every composition should have *one predominating feature* to which all else must be subordinated. A multiplicity of points of interest in the design leads to disruption of unity and distracts attention.

(d) *Stability*. Architecture, as will be shown later, is a *living art* and as such must give evidence of life and growth in its

make up. Like a tree deeply rooted and rising majestically,

spreading out its tapering branches and clothing them with foliage, so every architectural monument should rise from a strong, substantial base and grow lighter and more delicate as it mounts upward. A building must not be strong only; it must appear strong. To convince the eye of the perfect stability of a structure, materials which are suggestive of strength and inherently strong, such as granite or stone, should be used for the foundations of all buildings. The upper stories, particularly of such monumental edifices as cathedrals and office buildings, are generally made more delicate and ornamental than the lower floors.

Carrying the analogy of architecture to tree life still further, we find in the shape of the tree trunk, broad at the bottom and tapering upward, a valuable suggestion for the archi-

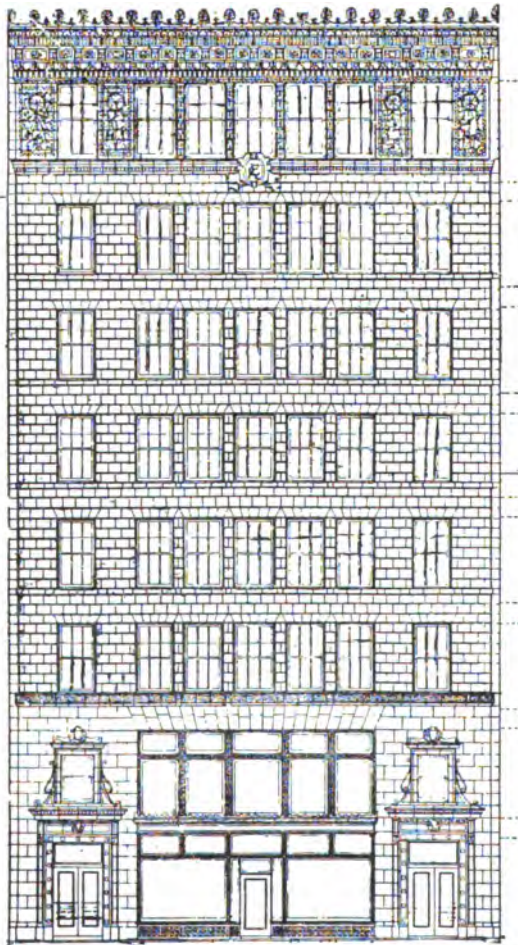

FIG. 11.—Exterior Divisions.

tectural designer. A building, if conditions permit, should be made pyramidal in form, the contraction perhaps not as sudden or evident as that in a tree but being powerfully suggestive of its growth and shape. This principle is illustrated in Plate III.

35. Architecture Epitomized. The main divisions of any building are similar to those of a column, namely, base, shaft, and capital. The base of the column corresponds to the base of the building and is the broadest part of the structure. The shaft corresponds to the main body of the building and is made up of vertical rows of windows between solid wall piers, just as the plain verti-

cal "arises" of an Ionic shaft enclose the semicircular voids of the channels. The cornice resembles the capital of a column in that the former always crowns a building and invariably is its most highly decorative feature.

A building is lacking in character unless the three divisions are plainly expressed. In the illustration given below (Fig. 11), this principle is shown to be applicable even to structures confined in narrow city lots. The three divisions are quite distinct. An appearance of strength is imparted to the base by the use of massive stones. The body is purposely kept plain to offset, by contrast, the richly decorated upper story.

SECTION III

MATERIALS OF CONSTRUCTION

BRICKWORK

36. Manufacture. Brick is made by submitting to a very high degree of temperature, prepared clay, which has been previously formed in molds to the required shape and size. The quality of brick depends upon the kind of clay used, the thoroughness with which the brick was dried before it is burned, and its position in the kiln.

37. Characteristics. Bricks should be uniform in size, firm in texture, and true in form. When two bricks are struck together they should emit a clear ringing sound; a dull note indicates an inferior quality. Good brick is practically indestructible, as is evidenced by the use of second-hand brick as a backing, or as the sole material for rear or side walls in new buildings. Add to this advantage of permanence the ease with which it is handled, its cheapness, and the innumerable shapes, sizes and colors in which it may be wrought, and you have in part

an explanation for the unwaning popularity of brick as a building material.

38. Classification. For all general purposes bricks may be divided into two classes: *common* and *face*. Common bricks are used for all rough work and for the backing of walls. Face bricks are used for the exterior of a wall.

Common bricks are graded according to their location in the kiln. "Hard" bricks are nearest the fire; they are very hard and brittle. "Soft" or "salmon" bricks are furthest away from the fire; they are underburned and comparatively soft. Between these two extreme courses are the "well burned" bricks, which are the best for building purposes.

Face bricks are classified according to the method employed in molding them. The two principal classes used in building construction are "pressed" brick, which are molded from dry or semi-dry clay, and "re-pressed" brick which are subjected to tremendous

pressure, after being molded into shape, while the clay is in a condition as plastic as soft mud.

39. **Sizes.** Bricks are made of different sizes, as shown by the following table:

| Brand. | Size of Brick. (Dimensions in Inches.) | | |
|-----------------------------|--|--------|------------|
| | Length. | Width. | Thickness. |
| Maine..... | 7½ | 3½ | 2½ |
| Baltimore..... | 8½ | 4½ | 2½ |
| Philadelphia..... | 8¾ | 4 | 2½ |
| North River, N. Y..... | 8 | 3½ | 2½ |
| Western States..... | 8½ | 4½ | 2½ |
| Peerless Brick Company..... | 8½ | 4½ | 2½ |
| "Roman"..... | 12 | 4 | 1½ |

The standard size of brick adopted by the National Brickmaker's Association is 8½×4×2½ inches for common brick, and 8¾×4½×2½ inches for face brick.

40. **Joints.** The mortar in the joints serves a triple purpose: First, it binds the whole wall into one solid mass; second, it fills the interstices between the bricks and thus prevents moisture from entering; and third, it distributes the pressure evenly by filling in all irregularities between the bricks.

The mortar near the surface of the joint is affected by changes of temperature, and in course of time it will crumble, water will enter and, when frost sets in, it will disintegrate. To prevent dislodgment **pointing** is resorted

to; the joints are raked out to a depth of one inch and are refilled with grout i.e., a thin mixture of one part cement and one part sand. Pointing improves the appearance of the wall, and protects the mortar in the joints from disintegration. Fig. 12 shows the three most common styles of pointing.

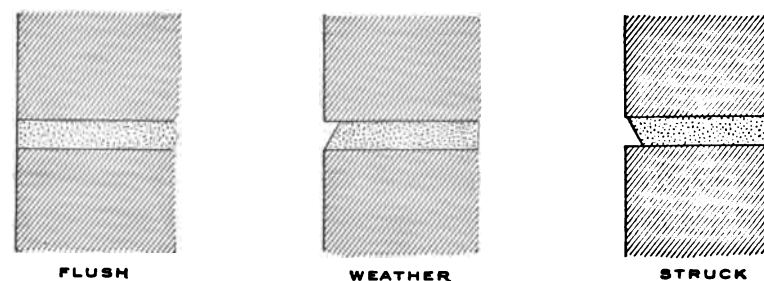

FIG. 12.—Brick Masonry Joints.

Common bricks in exterior walls are laid with joints varying in thickness from ¼ to ⅓ of an inch, and pressed brick with joints from ⅓ to ⅔ of an inch.

41. **Bonding.** In all brickwork continuous vertical joints should be avoided. Each brick should overlap the one it comes in contact with, above and below. This method of arranging bricks is known as *bonding*. Aside from the firm tie which results, bonding has the additional advantage of distributing the load which comes upon one brick over a larger number of bricks below; thus

in Fig. 13 the pressure coming upon *A* is transmitted to every brick within the triangle *ABC*.

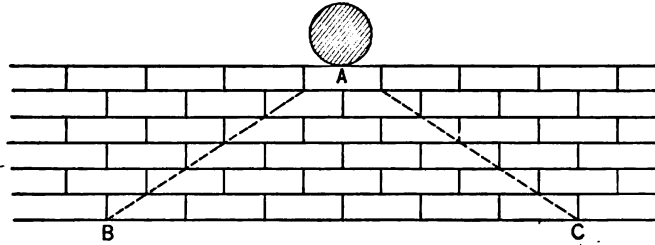

FIG. 13.—Distribution of Load.

42. Terms Used in Brick Work. Before proceeding with a description of the various kinds of bonds it will be advantageous for the student to familiarize himself with the principal terms used in connection therewith. See Plate VII.

A **header** is a brick whose length lies perpendicular with the face of the wall.

A **stretcher** is a brick whose length lies parallel with the face of the wall.

A **course** is a horizontal layer of brick in a wall and is of a depth equal to that of a brick and one mortar joint.

A **closer** is a section brick in the front of a wall to maintain the bond.

Bats are broken bricks and are designated by names indicating their size, e.g., three-quarter, half, or quarter bats.

43. Bonds. The three principal bonds in brickwork are: First, the *common bond* which is made up of several (usually five) continuous courses of stretchers, followed by one course of headers; second, the *English bond* which is laid in alternate courses of headers and stretchers; and third, the *Flemish bond* which consists of alternate headers and stretchers in each course. See Plate VII.

STONEMWORK

44. Building Stones. The three most common classes of building stones are granite, sandstone, and limestone.

Granite is a stone remarkable for its hardness and durability. The difficulty with which it is worked and its costliness confine its use to places where great strength is required, such as the foundations of public buildings, high office structures, and engineering works.

Sandstone is composed of sand cemented together. The color of the stone, its strength, and its durability are dependent upon the character of this cement. Sandstones are found in abundant quantities in all parts of the country. They are of a great variety and pleasing color and are easily worked. They are valuable for moderately heavy construction.

Limestone is composed of carbonate of lime. It is of a light gray color, is uniform in its texture and, owing to the facility with which it may be wrought, is an excellent

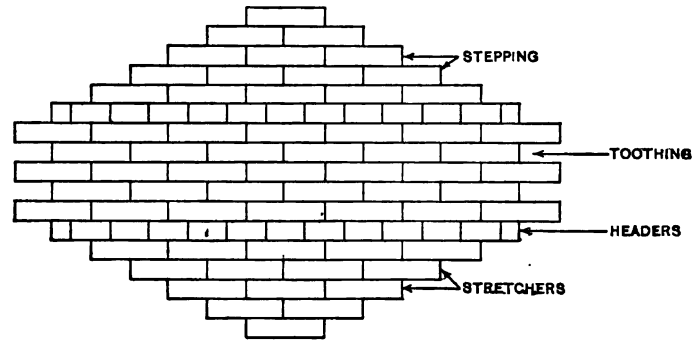

COMMON BOND

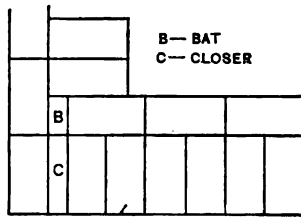

PLAN OF COURSE W

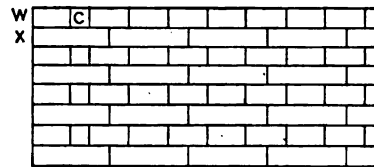

ENGLISH BOND

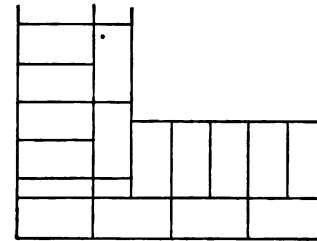

PLAN OF COURSE X

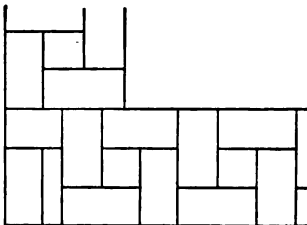

PLAN OF COURSE Y

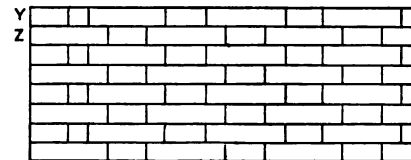

FLEMISH BOND

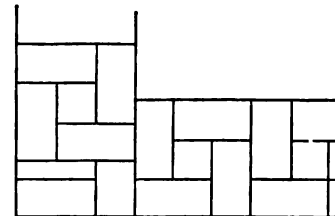

PLAN OF COURSE Z

material for carved work, trimmings etc. It absorbs more water, however, stains more quickly and is rarer than sandstone. **Marble** is the name applied to any limestone that is susceptible of a high degree of polish. Its rich and variegated colors make it especially suitable for interior decoration.

45. Walls. Masonry walls are distinguished by names descriptive of, first, the arrangement of the horizontal joints between the stone blocks and, second, the "dressing" of the stone. *Dressing* refers to the operation of shaping a stone and finishing its surfaces. Undressed blocks of stone are called **rubble**. It is the name applied to a stone that is used as it comes from the quarry. Stones partly dressed are known as **squared stones** or squared rubble. **Ashlar** is the term applied to a stone that is accurately cut and carefully dressed, and which is used as a material for facing walls. See Plate VIII.

Walls built of rubble masonry are divided into two general classes: Uncoursed rubble and coursed rubble. *Uncoursed rubble* masonry is composed of irregularly-shaped stones set up at random; and *coursed rubble* of stones levelled off at stated heights to a horizontal line. Coursed work permits of the following further classification: (1) *Rubble masonry worked up to courses* about every foot or 18 inches; (2) *regular coursed rubble* in which the joints are continuous.

The arrangement of courses in squared stone masonry

is similar to that of rubble masonry. In both classes of rubble walling *quoins*, that is, corner blocks, are often used as gauges for the heights of the courses.

The two principal classes of ashlar masonry are: First, *regular coursed ashlar*; second, *broken ashlar*. Ashlar backed up with rubble is called *rubble ashlar*, and if backed up with brick, *brick ashlar*.

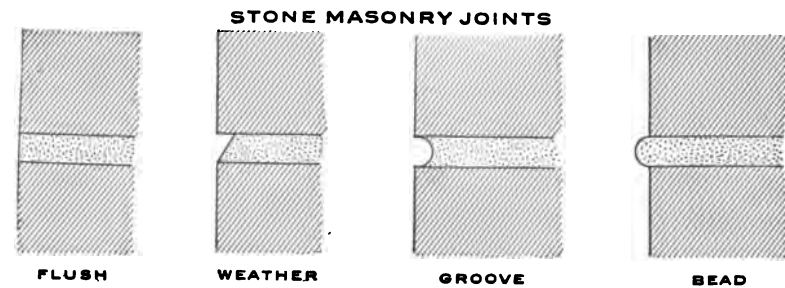

FIG. 14.

46. Joints in Masonry. The joints in stone masonry are raked out and refilled with a specially prepared mortar exactly for the same reasons that the joints in brickwork are pointed. Fig. 14 indicates the methods commonly employed in accomplishing this end.

CEMENT

47. Kinds. The two kinds of cement utilized for purposes of building construction are natural or Rosendale cement and artificial or Portland cement. Natural

RUBBLE

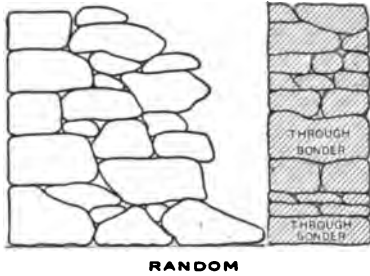

RANDOM

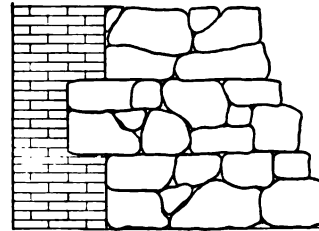

BUILT IN COURSES WITH BRICK QUINS AS GAUGES

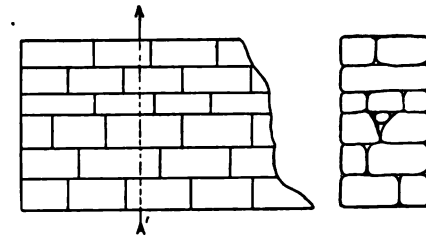

COURSED OR REGULAR COURSED RUBBLE

SQUARED RUBBLE

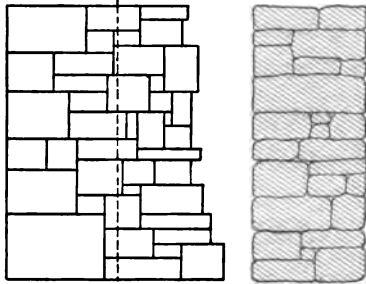

RANDOM OR REGULAR COURSED

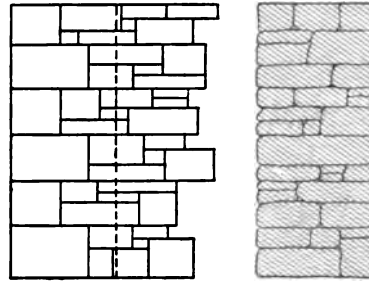

BUILT UP IN COURSES

ASHLAR

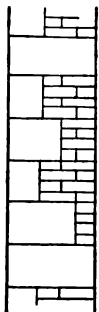

BRICK ASHLAR

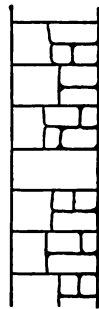

RUBBLE ASHLAR

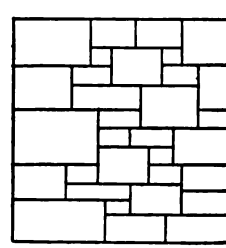

BROKEN ASHLAR

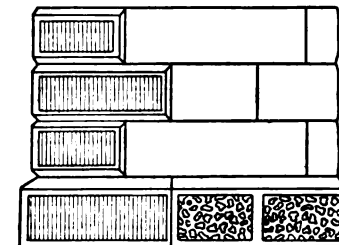

COURSED ASHLAR SHOWING QUINS AND BELT OR BASE COURSE

cement is so called because it is prepared directly from natural forms of limestone; it needs no artificial proportioning. The limestone is simply broken up into pieces and burned in a kiln.

Portland Cement is manufactured by mixing finely pulverized carbonate of lime in carefully determined proportions with clay, calcining the mixture at a very high temperature, and then grinding the burned product to an impalpable powder. Portland cement derives its name from its resemblance to the Portland stone of England where such cement was first made.

Natural Cement sets more quickly than Portland cement and for that reason is well adapted for work under water. Moreover, natural cement costs less than Portland, which fact accounts for the former's frequent use in building construction. Portland cement, on the other hand, is of superior strength. Its use is required by law for foundations, piers, bearing walls and other places supporting heavy loads.

MORTAR

48. Kinds. There are two kinds of mortar: Lime mortar and cement mortar. Whether lime or cement is used in the mixture the other ingredients are clean, sharp, coarse sand and water; only a sufficient quantity of the latter being added to reduce the mass of cement or

lime and sand (which have previously been thoroughly mixed) into a plastic condition.

The proportions to be used in mixing the ingredients of mortar are regulated by the New York Building Law as follows:

Lime Mortar. Lime mortar shall be made of one part of lime and not more than four parts of sand.

Cement Mortar. Cement mortar shall be made of cement and sand in the proportion of one part of cement, and not more than three parts of sand, and shall be used immediately after being mixed.

Cement and Lime Mortar. Cement and lime mortar mixed shall be made of one part of lime, one part of cement and not more than three parts of sand to each.

CONCRETE

49. Composition. Concrete is an artificial stone formed by proportionately mixing cement, sand, stone and water. The usual way of expressing proportions in concrete work is to indicate its ingredients in figures; thus, the expression 1:2:4 concrete means that one part cement, two parts sand and four parts aggregate have been used to make the product. The term "aggregate" is applied to the solid material (stone, gravel, or cinders) of a concrete mixture. Rough and irregular fragments of broken stone of different sizes, not too large, however, to pass through a

two-inch ring, form the best aggregate. The kind of aggregate used to form concrete determines its name. Thus we have "stone concrete," "gravel concrete," and "cinder concrete."

50. Reinforced Concrete. As its name implies, reinforced concrete is concrete in which steel has been imbedded to give additional strength and elasticity. It is a form of concrete that has passed beyond its experimental stage and has gained recognition as a material of the first rank in the construction of large buildings, bridges and other structures. Reinforced concrete construction has made tremendous strides in the last decade and it is now recognized as the material *par excellence* for heavy construction.

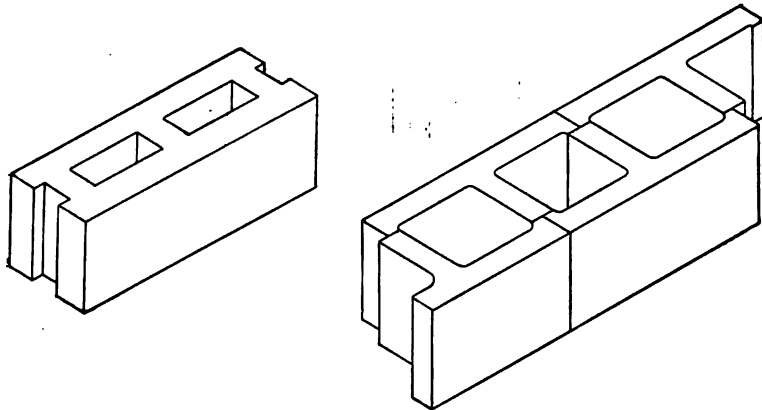

FIG. 15.—Concrete Blocks.

51. Concrete Blocks. Concrete blocks are molded from a mixture of 1 part Portland cement and 4 or 5 parts of sand and gravel, or stone screenings containing

grains of all sizes from fine to $\frac{1}{4}$ -inch. They are made in a variety of shapes and sizes, either solid or with one or more air-spaces separated by 1-inch concrete partitions called webs. Whether solid or hollow blocks are used in the construction of walls, a continuous cavity may be formed as suggested in Fig. 15.

The face of a block is either plain or ornamental; rock-faced, tool-faced, and paneled patterns are the most common styles of the latter type.

TERRA-COTTA

52. Manufacture. Terra-cotta is produced by forcing kneaded clay through molds, baking the product in kilns, and allowing it to cool slowly.

53. Ornamental Terra-Cotta. Terra-cotta is undoubtedly the best material for trimmings. It is practically indestructible by fire. Its plastic condition before baking makes it readily adaptable to the sculptor's art and skill. When an architectural feature is repeated, only one mold is required if terra-cotta is used. These facts, together with its comparative cheapness, explain its use as a substitute for stone. To add to its beauty terra-cotta is very often colored, the coloring substance being burned into the material.

54. Structural Terra-Cotta. There are three varieties of structural terra-cotta, porous, semi-porous and dense.

Porous terra-cotta is made of a mixture of clay and sawdust. During the burning process, the sawdust is consumed, leaving the terra-cotta full of holes, thus affording an admirable surface for plastering and holding firmly nails driven into it for securing slate, interior trim, etc. It is more fire-proof than either of the other classes, and is used chiefly as a covering for columns and girders and for partitions and furring.

Semi-porous terra-cotta is made by the mixture of ground coal instead of sawdust. It possesses greater strength than porous terra-cotta. It may be put to the same service as the porous and is employed in heavier construction.

Dense terra-cotta possesses great durability and strength and is used in places exposed to moisture and in arch construction. It is made of fire-clay and potter's clay or brick clay.

55. Terra-Cotta Blocks. Terra-cotta for building purposes is made of clay, molded into hollow tile blocks and hard burned. The interior of hollow tile is reinforced with $\frac{3}{4}$ -inch terra-cotta partitions called "webs," which strengthen the block and prevent it from twisting while drying. Hollow tile blocks are made of dense, semi-porous or porous material. For certain purposes hollow tile has no equal as a building material; it is permanent, fire-proof, water-proof, and vermin-proof.

The *size of block* most commonly used in building construction is 8 inches thick, 12 inches high, and 12 inches

wide, although several other sizes are made. The outer face of the block is grooved to receive the plaster, which may be applied to the tile without furring or lathing. See Fig. 16.

The rapid depletion of our forests and the consequent advance in the cost of lumber have long made imperative the need of a good substitute for wood. Hollow concrete

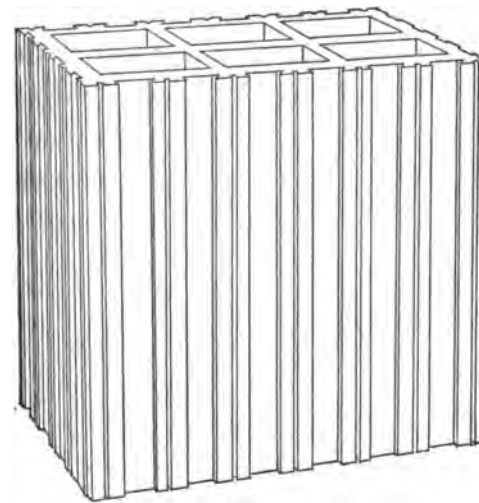

FIG. 16.—Hollow Terra-Cotta Blocks.

and terra-cotta blocks are the direct outcome of this demand. Although higher in first cost of construction, the saving effected in fuel and repairs and their durability and fire-proof qualities explain the rapid growth in favor of these materials, particularly for the exterior walls of country residences.

SECTION IV

BUILDING CONSTRUCTION

A. MASONRY

56. Site. The primary consideration in the development of the plans for a building is its location. This is determined largely by its function. But no definite steps can be taken until the size and shape of the plot and its surroundings are fully known.

57. Arrangement of Rooms. Having selected a site, the position of the house must be decided upon. To some extent the environs and approaches affect this, but to a greater extent the ultimate location is determined by the sunlight, particularly in the case of dwelling houses. All rooms should receive as much light and sunshine as the situation can be made to yield. The south and southeast are usually given up to bed chambers and living rooms, for then they will be cool in summer and warm in winter. The dining room should have an eastern exposure; here it will receive the early morning sunshine and be pleasant at all hours of the day. It is essential that this room be comfortable and cheerful at all seasons, for it is used by

the entire family more than any other room in the house. The north, owing to its less cheerful aspect, is best given to halls, stairways, and minor rooms.

Of course the arrangement of rooms above proposed is not always possible; a house built on a city lot, between tall buildings, may not lend itself to such a distribution. Still, the suggestions made should always be kept in mind and applied wherever practicable.

The site having been selected, the position of the house located, and the plans of the architect approved as to prospect of view and distribution of rooms, building operations may begin.

58. Waterproofing. The first operation in connection with building construction is testing the soil to ascertain the presence of clay. Clay is a treacherous material because it retains the water which inevitably settles into a new excavation. The water thus entrapped forces its way through the foundation walls, disintegrates the mortar in the masonry and eventually works its way up, causing decay in the woodwork, and rendering the building unsafe

and unsanitary. The remedy is simple; give the water a chance to escape. This is done by filling in the trench outside of the wall, to a distance of at least one foot, with broken stone and gravel. Laid dry, the broken stone or gravel acts as a drain and conveys the water away from

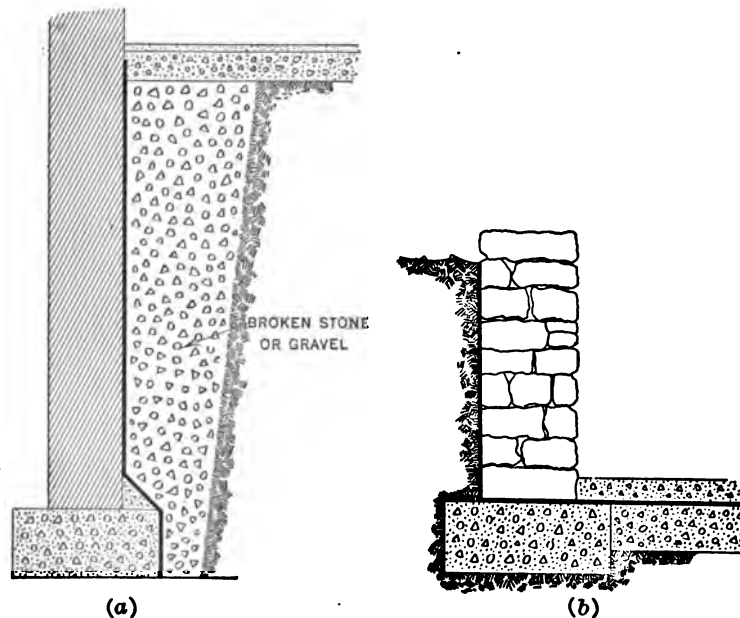

FIG. 17.—Waterproofing with Asphaltum.

the walls. As a further precaution, the walls are made waterproof with one heavy coat of asphaltum, applied on the outside and extending from the grade down to and overlapping the footings, as in Fig. 17 (a), or, better still,

as shown in 17 (b), in which case the coating of asphaltum is carried down the wall to the top of the footing and then continuously along the cellar floor.

A method, more expensive at first, but cheaper in the end, is to use a tile drain, carrying it around the house and giving it a fall of approximately one inch in ten feet to admit of the ready flow of water. See Fig. 18.

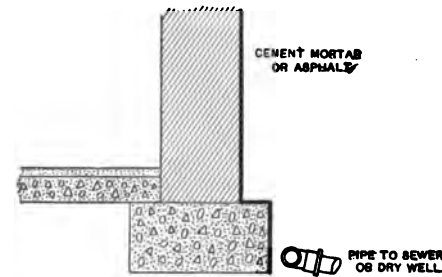

FIG. 18.—Waterproofing with Tile Drain.

Fig. 19 is a section through a foundation wall showing the manner of waterproofing used in Government buildings.

59. Batter Boards. When the building is ready to be staked out, architect and contractor meet upon the ground and set up the *batter boards*. These consist of planks securely nailed to posts, see Fig. 20, which are placed at the principal corners of the building. They are set about five feet from the outside walls so as not to interfere with the operation of excavating. Into these batter

boards notches are cut, and lines are stretched to coincide with the exterior and interior faces of the building.

60. Excavations. Excavating now proceeds in conformity with the lines indicated on the batter boards.

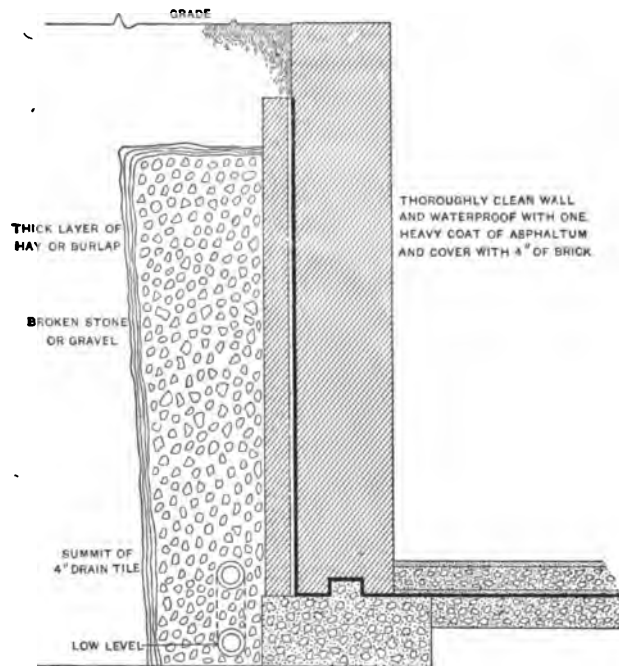

FIG. 19.—Government Method of Water-proofing.

Excavations for buildings must always be of sufficient depth to insure against the action of frost. In New York City the minimum depth, as prescribed by law, is four feet.

The excavation should always be made one foot wider all around than the outside of the foundation wall. This space is needed for the mason, when setting up the stone or brick, or for the carpenter, when erecting forms for concrete walls.

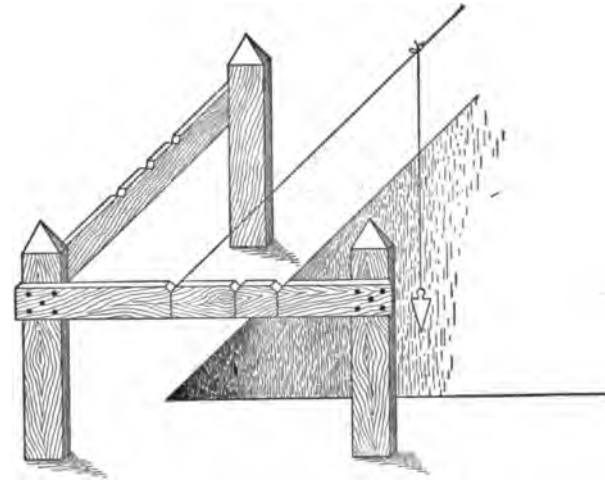
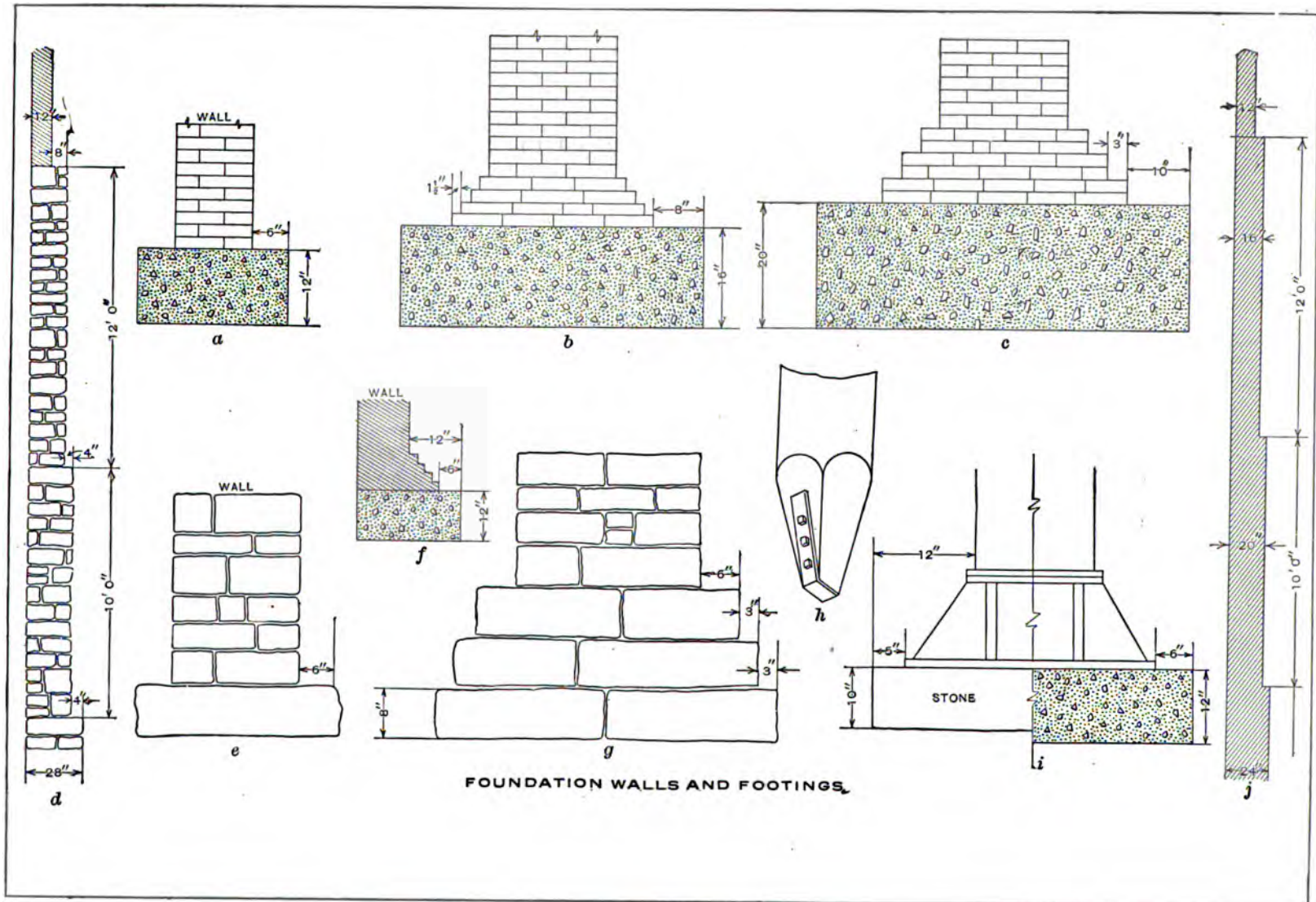

FIG. 20.—Stakes and Batter Boards in Place.

61. Footings. Footings serve the purpose of distributing the weight of the structure over a larger area of surface. All masonry walls are liable to settle and all soils are, to a more or less degree, compressed by the superimposed loads. Consequently, by increasing the area of the bearing surface at the base of a wall, the pressure upon each square foot is reduced and a more uniform settlement results. See Plate IX.



FOUNDATION WALLS AND FOOTINGS.

If the projection of the footing from the face of the wall is made too small, the wall will sink; if made too wide, the footing will split. The necessity, therefore, of careful calculation in the design of foundations becomes apparent. The following regulations of the New York Building Code will be found of great assistance in this regard: "The footing or base course shall be of stone or concrete or both, or of concrete and stepped-up brick work of sufficient thickness and area to bear safely the weight to be imposed thereon. If the footing or base course be of concrete, the concrete shall be not less than twelve inches thick. If of stone, the stone shall be not less than two by three feet and at least eight inches in thickness for walls; and not less than ten inches in thickness if under piers, columns or posts. The footing or base course, whether formed of concrete or stone, shall be at least twelve inches wider than the bottom width of the walls, and at least twelve inches wider on all sides than the bottom width of said piers, columns, or posts."

"If stepped-up footings of brick are used in place of stone, above the concrete, the offsets, if laid in single courses, shall each not exceed one and one-half inches, or if laid in double courses, then each shall not exceed three inches, offsetting the first course of brickwork, back one-half the thickness of the concrete base, so as to distribute properly the load to be imposed thereon."

62. Foundation Walls. The term "foundation walls" refers to that part of the building which is below the surface of the ground and which supports the superstructure. Foundation walls are built of brick, stone or concrete. Their thickness is governed by law. In New York City the following regulations maintain: "If built of rubble stone, or Portland cement concrete, they shall be at least eight inches thicker than the wall next above them. . . . (see Plate IX.)

If built of brick they shall be at least four inches thicker than the wall next above them. . . .

. . . The foundation walls of frame structures if of stone, shall be not less than eighteen inches thick, and if of brick not less than twelve inches."

Foundations on marshy grounds are formed by driving "piles" into the ground below the walls. **Piles** are generally made of trunks of trees and are pointed at one end and flat on the other. In heavy construction the pointed ends of the piles are shod with iron as shown at *h*, Plate IX, to prevent them from splitting, while the tops are ringed with iron to avoid "brooming." When driven to solid bearings, the heads of the piles are cut off at a level, heavy planks are laid across, and the building is erected.

63. Exterior Walls. The exterior walls of all buildings except frame may be built of stone, brick, concrete, steel or iron. The thickness of masonry walls varies

according to the kind of material used, area of surface covered and the height and function of the building. A partial table of the thickness of outside walls as required by the New York City Code follows:

THICKNESS OF MASONRY WALLS

(New York Building Code)

DWELLINGS

| Height of Building. (feet) | Foundation. (inches) | | Exterior Walls. Brick. |
|-------------------------------|-------------------------|--------|---|
| | Brick. | Stone. | |
| 40 | { 12 | 18 } | 12" front and rear; 8" side |
| | { 16 | 20 } | |
| 40 to 50 | 16 | 20 | 12" |
| 50 " 60 | 20 | 24 | 16" first story; 12" above |
| 60 " 75 | 20 | 24 | 16" lower 25'; 12" above |
| 75 " 100 | 24 | 28 | 20" lower 40'; thence 16" for 35'; thence 12" to top |
| WAREHOUSES | | | |
| 40 | 16 | 20 | 12" |
| 40 to 60 | 20 | 24 | 16" lower 40'; 12" above |
| 60 " 75 | 24 | 28 | 20" lower 25'; 16" above |
| 75 " 100 | 28 | 32 | 24" lower 40'; thence 20" for 35'; thence 16" to top |

64. Masonry Walls. Walls built of brick, stone, concrete, concrete block, or terra-cotta block are called *masonry walls*. Compared to wooden buildings those built of masonry, although more expensive in initial cost, are more permanent, less expensive to maintain, more

attractive, and decidedly more fire-proof. The remainder of this section will be devoted to a discussion of the comparative advantages and disadvantages of masonry materials and to a brief description of the essential points of construction employed in each system. Frame construction will be treated separately.

65. Brick Construction. Bricks are laid by spreading a layer of mortar on top of a course of brick, shoving the bricks of the course being laid into position, and tapping them gently until the specified thickness of joint has been obtained. A good piece of brickwork has every course level and every angle plumb. Bricks should be thoroughly saturated with water before being laid, particularly in warm weather, because a dry brick absorbs the moisture from the mortar of the joints thereby rendering them weak and ineffective.

66. Bonding the Angles. When all the walls of a brick structure are built up simultaneously, as they should be to insure equal settlement, the manner of *bonding the angles* is a simple matter. If, however, it is found impracticable to carry up all the walls together, the wall erected first should be built with toothings as shown in Fig. 21. To further strengthen the angles, wrought iron anchors are built into the wall, as illustrated in the same cut. The New York Building Law has this to say in connection with bonding angles:

“In no case shall any wall or walls of any building be carried up more than two stories in advance of any other wall, except by permission of the Commissioner of Buildings having jurisdiction. . . . The front, rear, side, and party walls shall be properly bonded together, or anchored to each other every six (6) feet in their height by wrought-iron tie-anchors, not less than one and one-half ($1\frac{1}{2}$) inches by three-eighths ($\frac{3}{8}$) of an inch in size, and not less than twenty-four (24) inches in length. The side anchors shall be built into the side or party walls not less than sixteen (16) inches, and into the front and rear walls, so as to secure the front and rear walls to the side or party walls, when not built and bonded together.”

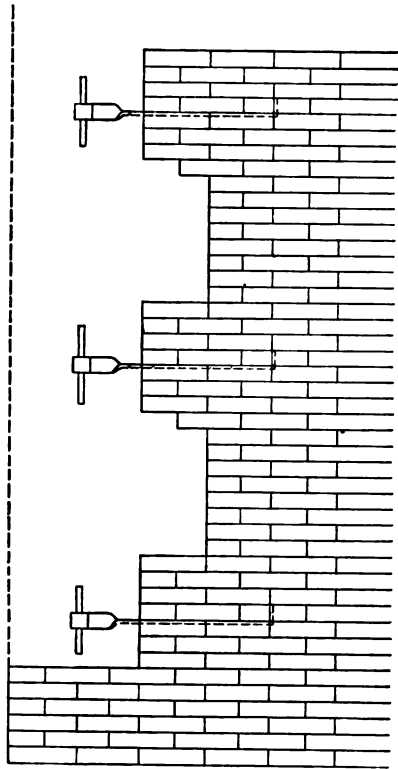

FIG. 21.—Brick Wall with Toothings and Iron Anchors.

... The front, rear, side, and party walls shall be properly bonded together, or anchored to each other every six (6) feet in their height by wrought-iron tie-anchors, not less than one and one-half ($1\frac{1}{2}$) inches by three-eighths ($\frac{3}{8}$) of an inch in size, and not less than twenty-four (24) inches in length. The side anchors shall be built into the side or party walls not less than sixteen (16) inches, and into the front and rear walls, so as to secure the front and rear walls to the side or party walls, when not built and bonded together.”

67. Floor Joists. When the walls have been carried up the required height, the floor beams are laid as shown in Fig. 22. The ends of the joists are beveled so that in case of fire they may fall without carrying the brick-work above with them.

It is a wise practice to anchor about every fifth joist into the wall. If this were not done, the walls would be thrown outward when settlement takes place in the foundation. The wrought iron anchor is spiked to the side and near the bottom of the joist. The nearer it is placed to the top of the beam the greater will be the danger of dislodgment of the wall above in the event of fire.

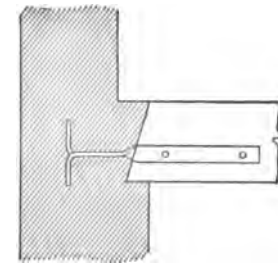

FIG. 22.—Showing Method of Setting Wood Beams in a Brick Wall.

68. Furring. Contrary to popular belief, brick walls are not absolutely waterproof. Moisture will penetrate in a driving rain storm and stain the wall paper or discolor the plaster within. To overcome this defect the walls are often *furred*,—that is to say, strips of wood $1'' \times 2''$ or $2'' \times 3''$ are nailed at intervals of 12 or 16 inches against the inner surface of the wall and the lathing and plastering is applied on these strips. The air spaces left between the wall and plaster serve as an insulation and prevent the passage of moisture. There are serious

objections, however, to the use of these furring strips; first, coming in direct contact with the damp brick wall, the wood will soon decay; second, the extra labor and material involved add to the cost of the building; and third, furring strips of wood increase the fire risk. In paragraph 78 a method of furring is suggested and illustrated that obviates all difficulties except that of cost.

As the interior of a brick house is usually constructed of wood we shall postpone the discussion of interiors until the section on Frame Construction.

69. Stonework. Houses built of rubble, dressed or undressed, coursed or uncoursed, whatever may be the defects in their construction, are decidedly attractive and picturesque; while those built of solid stone or of brick or concrete faced with stone, present an appearance of strength and grandeur that cannot be duplicated with any other material.

The weak point in connection with the construction of ashlar masonry or rubble work, is the union of the stones. This difficulty is in a great measure overcome by the introduction of large stones which extend entirely through the wall, "*through bonders*", or three quarters the thickness of the wall (*three-quarter bonders*). The number and position of these bond stones are regulated by the New York Building Code as follows:

"All stone walls twenty-four inches or less in thick-

ness shall have at least one header extending through the wall in every three feet in height from the bottom of the wall, and in every three feet in length, and if over twenty-four inches in thickness, shall have one header for every six superficial feet on both sides of the wall, laid on top of each other to bond together, and running into the wall at least two feet."

In case the wall should settle, through bonders are apt to split, hence two-third or three-quarter bond stones are recommended. The latter should be arranged alternately from opposite faces of the wall so as to distribute the weight more effectively. In ashlar walls the stone facing is secured to the rough masonry backing by means of metal clamps which must be dipped in hot asphalt or coal-tar to prevent rust. It is a good plan to build up the backing in combination walls to levels that will coincide with the horizontal joints of the facing material; this insures a more equal settlement and prevents separation.

Stone walls must be furred, if plastered, for they are more subject to the penetration of moisture than are brick walls.

Rubble walls of the same thickness as brick walls are weaker; hence, rubble walls must be made thicker. Furthermore, a great quantity of mortar is required to bind the irregular stones of rubble masonry together, thus increasing their liability to unequal settlement.

70. Concrete Construction. The manner of **mixing** the ingredients and of laying concrete, determine its quality. The most satisfactory results are obtained if the materials are machine mixed. If mixed by hand, the method is as follows: Sand and cement are spread upon a clean, wooden platform and mixed dry, shoveling them over at least twice. Water is then added and again the mixture is turned over. Between layers of this mass, the aggregate, which has been previously drenched and drained, is distributed evenly and the whole mixture vigorously worked over at least twice. The resulting product should present a uniform color and should have every stone coated with mortar.

71. Laying Concrete. Concrete should not be dumped in place from a high altitude for if that is done the ingredients will separate. It should be deposited in continuous layers and tamped to eliminate voids; the tamping should continue until free water appears on the surface.

72. Forms. The plastic condition of fresh concrete requires the use of *forms*, which are usually made of wood. They must be water-tight to prevent the escape of cement or mortar, and they must be thoroughly braced or held together by various mechanical devices to withstand the shocks of moving men and machinery and the pressure of the wet concrete. Fig. 23 illustrates an excellent mold for a column and typifies, at the same

time, the usual method of erecting and clamping forms or centers for concrete work.

Great care must be exercised in every stage of the erection of concrete work. In addition to their rigidity, molds must conform accurately to the lines of the finished work. For exposed faces, the surface next to the concrete is dressed. The forms must be carefully removed, and this should be done only after the concrete has thoroughly set and hardened. The length of time the molds should be left in position depends upon: First, weather conditions; second, the kind of cement used; third, the thickness of the concrete; and fourth, the amount of water used in mixing.

Generally a single set of forms can be made to serve for the construction of the whole of a moderate sized building. When one floor has hardened sufficiently, the forms are removed for use in the floor above. Molds must be scrupulously cleaned before being used again.

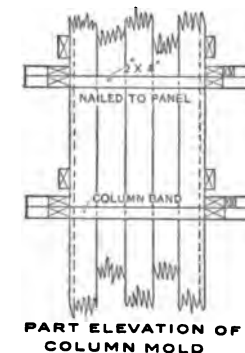
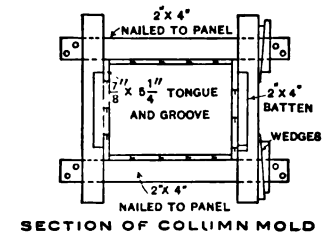

FIG. 23.—Details of Column Molds.

73. Advantages and Disadvantages of Concrete. Concrete is indestructible and fire-proof. It is stronger and cheaper than either brick or stone; nevertheless it has its disadvantages. It is a conductor of heat and cold; it is open to the same objection, when plastered, that was noted in the case of all other masonry walls so far discussed; it lacks the charm of brick and the picturesqueness of stone, presenting a cold and uninviting exterior.

74. Reinforced Concrete. The general observations made under concrete, in regard to mixing and laying the materials and to the setting and removal of forms, apply equally to reinforced concrete.

When subjected to compression, as in a column, plain concrete can stand heavy loading; but when subjected to tension or pull, as in a beam, it is liable to fracture in the same manner as stone under similar conditions, hence the necessity for reinforcement.

Reinforced concrete, owing to its homogeneity and great strength, may be used as a substitute for steel frame construction.

Reinforcement is effected by imbedding twisted or corrugated steel rods in the mixture when it is placed in the forms. The systems and methods are too numerous and varied to be treated here. A typical method is shown in Fig. 24.

75. Concrete Blocks. Concrete block as a material for the construction of exterior walls, and in fact, as a building material in general, is looked upon with suspicion

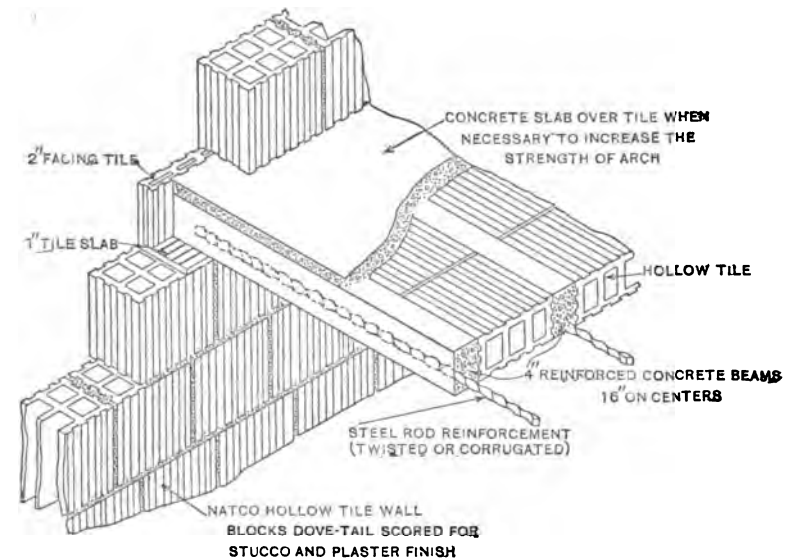

FIG. 24.—Detail of Wall Construction of Hollow Tile with Fireproof Floor of Hollow Tile and Reinforced Concrete Beams. The ceilings may be left flat, ready to receive the plaster from the concrete. Beams may be dropped down 2 or 3 inches, as required, to give the beam ceiling effect so often desired in residences.

by architects and builders because of the poor quality of product that is commonly turned out under that name. As ordinarily made, concrete blocks are brittle and porous and are therefore worthless as a building material. If

properly made and used, however, if the mixture is sufficiently rich and the aggregate carefully graded to reduce the percentage of voids to a minimum, if the surface is effectually waterproofed and the whole block is properly cured, it forms an excellent building material. It combines all the advantages of brick and stone and in addition costs less and is much more rapidly erected. It does away with the expensive forms required in monolithic work and makes skilled labor unnecessary. Among other advantages that favor concrete blocks are the economic use of material and their sanitary construction. The air chambers in the hollow blocks prevent moisture from passing into the interior of the house, thus rendering it dry and healthful.

Concrete blocks when used for foundation walls of frame buildings should either be solid, or, if hollow, filled with concrete as shown in (a) Fig. 25, and in either case they should be thoroughly waterproofed. In some localities, particularly in the western part of the United States, where building laws permit the use of cement or concrete blocks for all manner of buildings and all parts thereof, the methods employed for terra-cotta construction, as illustrated in Figs. 26, 27, 28, are applicable. See also (b) Fig. 25.

Houses built of blocks present a dreary aspect because of the exact similarity of each block in color and shape.

This deadly monotony, however, may be somewhat relieved by covering the surface with cement plaster.

76. Terra-Cotta Tile. Houses built of hollow terra-cotta tile are practically imperishable. There is no building material superior to hollow tile in fire-resisting and damp-proof qualities. Its use is permitted by all building laws wherever an absolutely fire-proof structure is demanded. Plaster cannot be applied directly to brick or stone because they are permeable; whereas hard-burned tile is as nearly waterproof as any such material can possibly be. The "cells" or hollow spaces in the blocks prevent any little moisture that penetrates the outer wall from going any further by conducting this moisture to the bottom of the wall.

The tile should be set on end to bring the cells in the block vertical. Thus laid, full advantage is taken of its cellular construction. It permits the passage of pipes and electric wires from floor to floor, facilitates reinforcement with steel rods and concrete in case of necessity, and above all, affords a superior insulation against heat and cold, insuring a warm house in winter and a cool interior in summer.

77. Tile Construction. Briefly, the construction of a hollow tile house is as follows: The cellar or foundation walls may be built of concrete, brick, stone, or 12-inch vitrified hollow tile, laid in Portland cement mortar, as

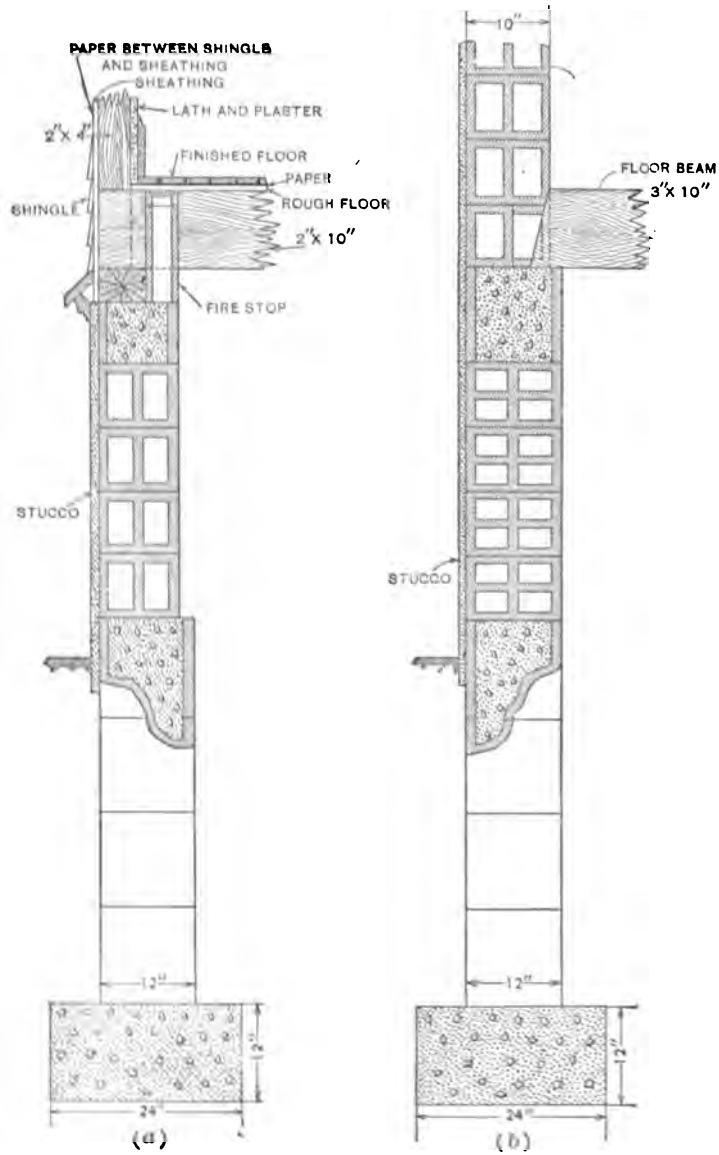

FIG. 25.—Concrete Block Construction.

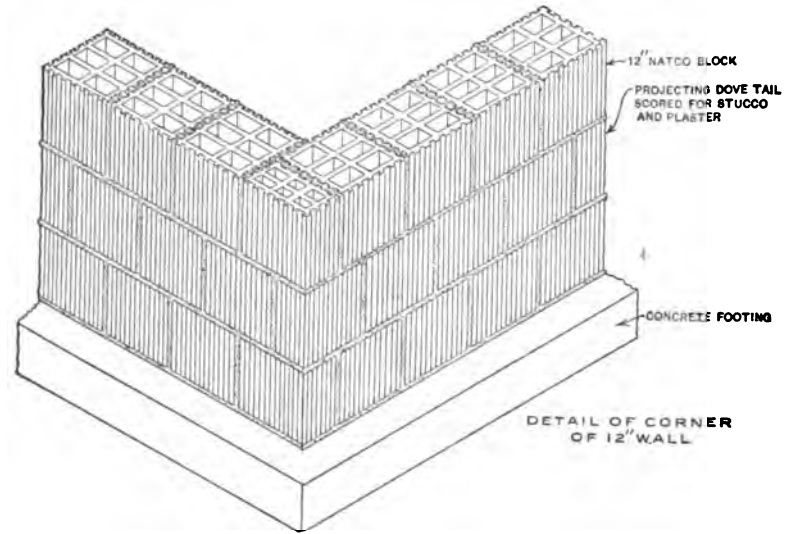

FIG. 26.—The above Details show Standard Hollow Tile Construction for Foundation and Superstructure.

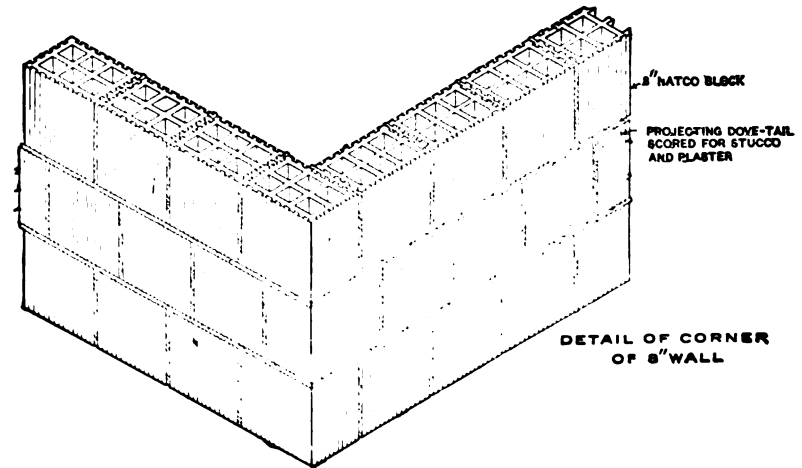

FIG. 27.—Detail of Corner of 8" Hollow Tile Wall.

illustrated in Fig. 26; the exterior walls are built of blocks 8 inches thick, 12 inches long, and 12 inches high;

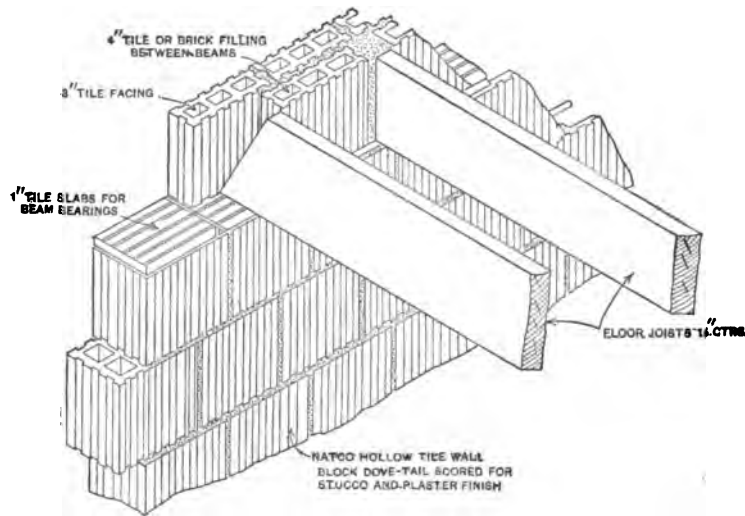

FIG. 28.—Detail of Wall and Floor Construction for Hollow Tile Walls with Wood Floors.

the floors and roof are generally constructed of 4-inch reinforced concrete beams spaced 16 inches on centers with hollow tile blocks between, Fig. 24; or, if economy is

desired, wood floor beams and rafters may be used as shown in Fig. 28. Partitions are built in the same manner as exterior walls except that a smaller tile, 3'×12'×12', is used.

Terra-cotta as a substitute for stone, besides possessing the advantage of cheapness noted in paragraph 53, offers, in addition, greater resistance to heat and is superior in weathering qualities.

78. Tile Backing for Walls. Tile is very often used as a *backing* for a brick veneered wall. The advantages of this combination are: First, that it is more rapidly erected, and second, its cellular construction makes it more damp-proof and sanitary than a solid wall of brick, stone or concrete. Figs. 29 and 30 illustrate two methods of securing face brick to hollow tile backing.

An effective method of checking the passage of moisture through solid walls is to line the interior with furring blocks of dense, semi-porous, or porous terra-cotta, as shown in Fig. 31. These blocks are 1½' or 2' thick and 12' square.

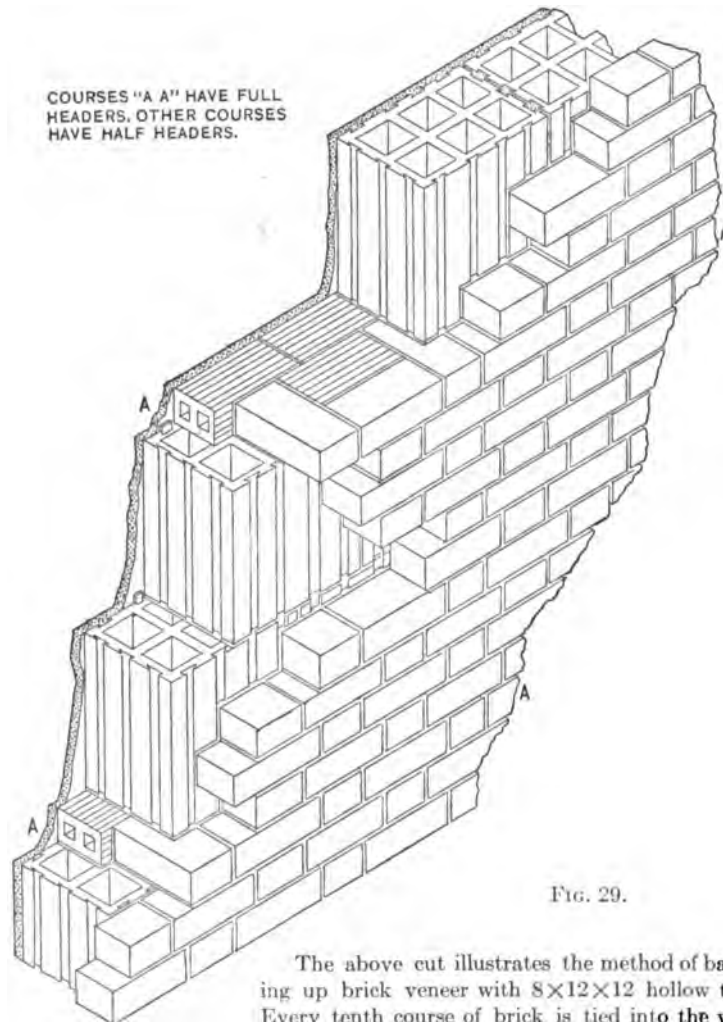

FIG. 29.

The above cut illustrates the method of backing up brick veneer with $8 \times 12 \times 12$ hollow tile. Every tenth course of brick is tied into the wall with a full header which is backed up with a row of hollow brick, as shown in the drawing. All other courses have bats or half headers butting up against the block. This method of construction ties the tile and the brick in an absolutely rigid manner.

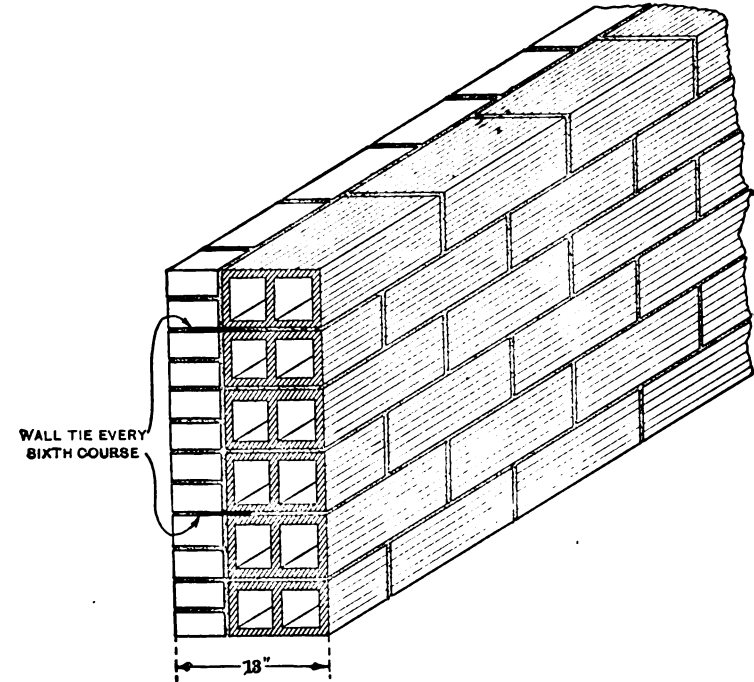

FIG. 30.—A more common method of securing the brick veneer is by metal wall ties.

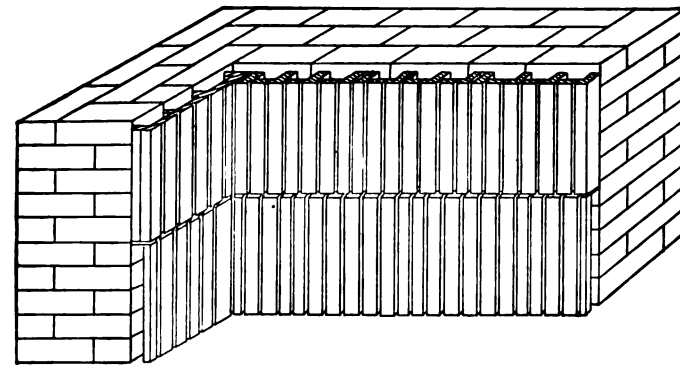

FIG. 31.—Terra-Cotta Wall Furring.

SECTION V

BUILDING CONSTRUCTION

B. FRAME

79. **Sill.** In commencing the erection of a frame structure, see Fig. 32, the first piece of timber laid is the sill;

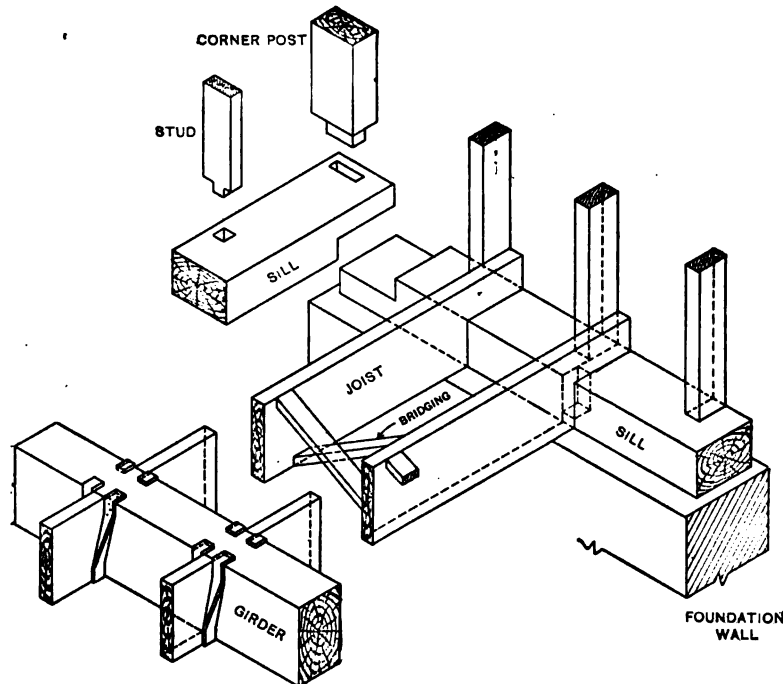

FIG. 32.—Framing Details.

this is placed directly upon and carried around the foundation wall. To insure perfect adhesion, and thus prevent cold drafts from entering the house, the under side of the sill is painted and imbedded in mortar. The sill is made usually either 6"×6", or 6"×8". It should be set back at least one inch from the outside face of the foundation wall to allow for exterior finish.

80. **Girders.** Girders are placed in the cellar or basement to correspond with the main divisions of the plan. They are generally 6" or 8" wide and from 8" to 12" deep. At intervals of about eight feet they are supported by brick or concrete piers, steel columns filled with concrete, or wooden posts.

81. **Joists.** After the sill is laid, the first floor beams are set up and immediately covered with rough boarding to afford, first, a working platform, and second, a storage underneath for building materials.

If the floor beams extend across the building, they rest on the sill, with heels on the foundation wall. If the building is more than twenty feet wide, girders must be used

to support the beams. Floor beams are spaced twelve or sixteen inches, center to center, and are two or three inches thick and from eight to twelve inches deep, the depth and spacing depending upon the span and the load to be carried.

Joists should be bridged once in every eight feet of their length with 1"×3" or 2"×3" scantlings, nailed crosswise between each pair. **Bridging** stiffens the beams by preventing them from buckling sideways. It also materially increases their carrying capacity by helping to distribute the load over a greater number.

82. Headers and Trimmers. Where stairs, chimneys, or elevators occur in a floor the beams are framed around the opening with heavier beams known as headers and trimmers. *Trimmers* run parallel with the common joists and *headers* at right angles. Headers are either tenoned into trimmers, or, preferably, are hung to them by stirrup-irons, sometimes called bridle irons, as shown in Fig. 33. *Tail beams* are held in position in a similar manner.

83. Corner Posts. Posts, 4"×4", 4"×6", or 4"×8", extending in one piece from sill to plate, are set up at each corner of the building and, if necessary, at intermediate points along the wall. The spaces between the corner posts are filled in with 2"×4" timbers, called **studs**.

84. Plate and Rafters. The *plate* is a 4"×4" or 4"×6" timber, corresponding to a sill, and is laid upon

the posts and studding to support the *rafters*,—the inclined framing members of a roof.

85. Framework. In the erection of the exterior frame two methods of construction are available—*balloon framing* and *braced or full framing*. The method of procedure

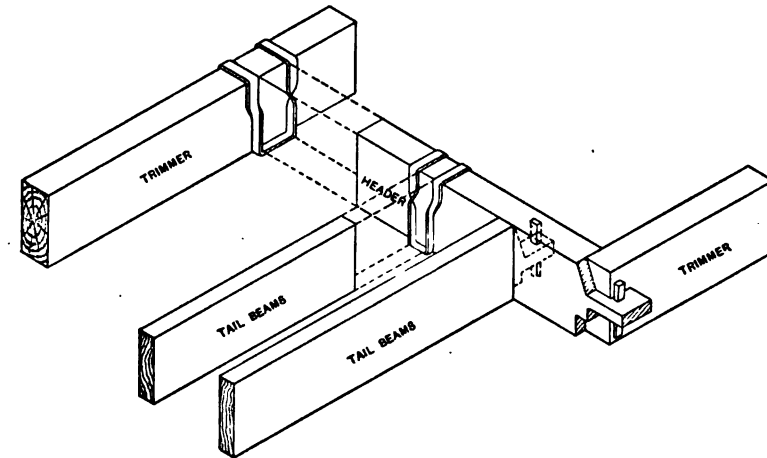
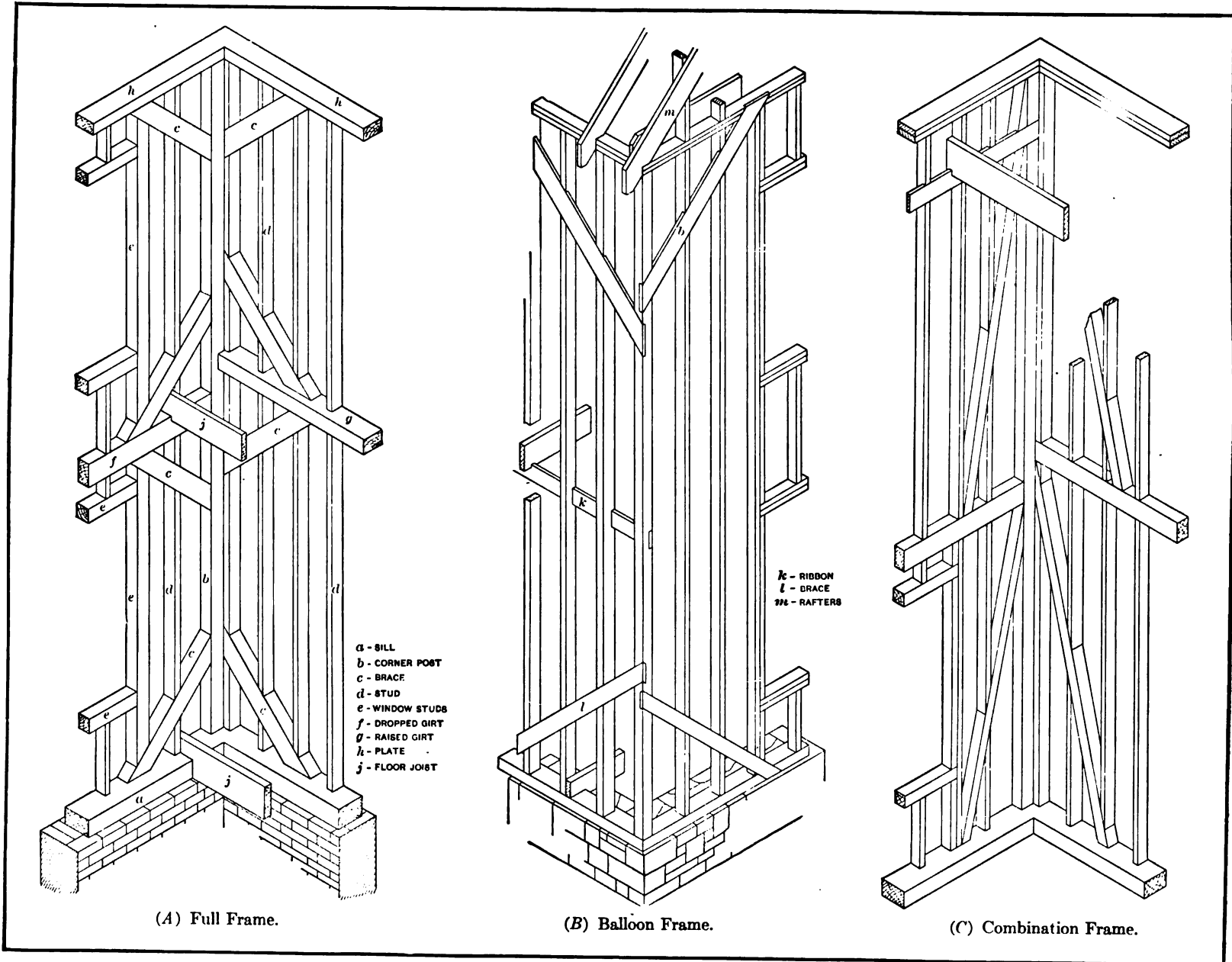

FIG. 33.—Framing Openings.

is practically the same in both cases, viz: The sill is laid, the corner posts are set up, and the studs, joists, plate, and rafters follow in the order mentioned.

86. Full Frame. In the full frame, Plate X (A), heavy timbers are used, mortised and tenoned together, accurately cut, and carefully fitted. All angles are reinforced with diagonal braces, securely tenoned and pinned into the vertical and horizontal members of the frame.



The outer ends of the joists of all floors above the first, bear upon dropped or sunk *girts*; these are horizontal timbers six or eight inches deep and of a thickness equal to that of the posts into which they are tenoned and pinned. Raised girts run parallel with the joists and are set as shown at *g*. Their function is to afford a nailing surface for the flooring, besides, of course, adding to the stability of the structure.

The advantages of the braced or full frame method of construction are its rigidity and slow burning qualities, but the extra cost of labor and materials involved in its erection has caused it to be discarded for a lighter, more easily erected and less expensive construction.

87. Balloon Frame. In the balloon frame, Plate X (*B*), all timbers are secured by nail and spike; almost no cutting is necessary, thus the full strength of the timber is preserved. In this system of framing the girts are omitted; the studs are in one piece from sill to plate and they are securely spiked to both. The intermediate floor beams rest on a 1"×6" piece called a *ribbon* or *ledger board* (*k*), which takes the place of the sunk girts in the full frame. The ribbon is inserted in notches cut on the inside face of all upright members. Braces (*l*) are omitted in all but the best frames.

88. Combination Frame. To overcome the excessive cost of the braced frame and the lightness and insecurity

of the balloon frame, a combination of both methods has been devised. Having been approved by the building laws of all localities, the combination frame is gaining in popularity and is gradually superseding other methods. The lower part of a house constructed on the combination frame method is built along lines described for the full frame. The sill is mortised to receive posts, studs, joists, and braces. The braces which are frequently only spiked are much longer and not quite so heavy, consisting of 2"×4" or 3"×4" pieces placed diagonally from the sill to the girts and from the girts to the plate. Girts are used for all floors except the attic. The construction of the upper part of the house follows the balloon method. A plate, consisting of two 2"×4" pieces of timber, is securely spiked on top of the studding and posts, which must be cut to a level to insure alignment. The studding is spiked to the plate and tenoned into the sill. The attic floor beams rest either on the plate or a ribbon. The rafters are notched over the plate and spiked to it. See Plate X (*C*).

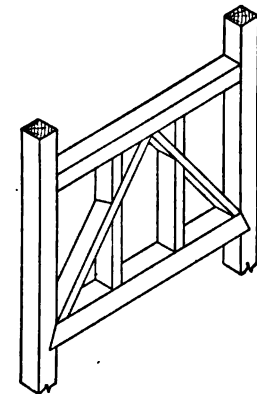

FIG. 34.
Truss Over an Opening.

Whichever system of construction is employed **double studs** are placed at the sides and at the top and bottom

of all door and window openings. If openings exceed four feet in width they must be trussed on top as shown in the accompanying sketch, Fig. 34.

89. Partitions. Partitions are of two kinds,—bearing and non-bearing. They are commonly constructed of 2"×4" studding, those in the bearing partitions being set twelve inches and those in the non-bearing partitions, sixteen inches on centers; the spacing being adapted to the length of the laths which are always forty-eight inches.

Bearing or "fore-and-aft" partitions help support the floor beams. They rest directly over one another and are supported in the cellar by girders. When thus superimposed, they "shall run down between the wood floor beams and rest on the top plate of the partition below and shall have the studding filled in solid between the uprights to the depth of the floor beams with suitable incombustible materials." (N. Y. Code.) See Fig. 35.

When partitions are built over one another there will be a minimum settlement due to the shrinkage of the timbers. Any deviation from the method of constructing bearing partitions as above described and illustrated

will increase shrinkage and cause cracks to appear in the plastered walls and ceilings, floors to sag, and prevent doors built in such partitions from opening and closing readily.

Non-bearing partitions are supported by two joists spaced about six inches apart. The manner of setting the studs and joists is clearly illustrated in Fig. 36.

Partition studs, as well as those forming the frames of exterior walls, are stiffened by rows of diagonal or horizontal *bridging* composed of 2"×4"

pieces set in between the studding as shown at *a* and *b* in Fig. 36. These pieces also act as fire and vermin stops.

90. Roof. The placing of the roof timbers completes the framing of the structure. A roof is an inclined floor;

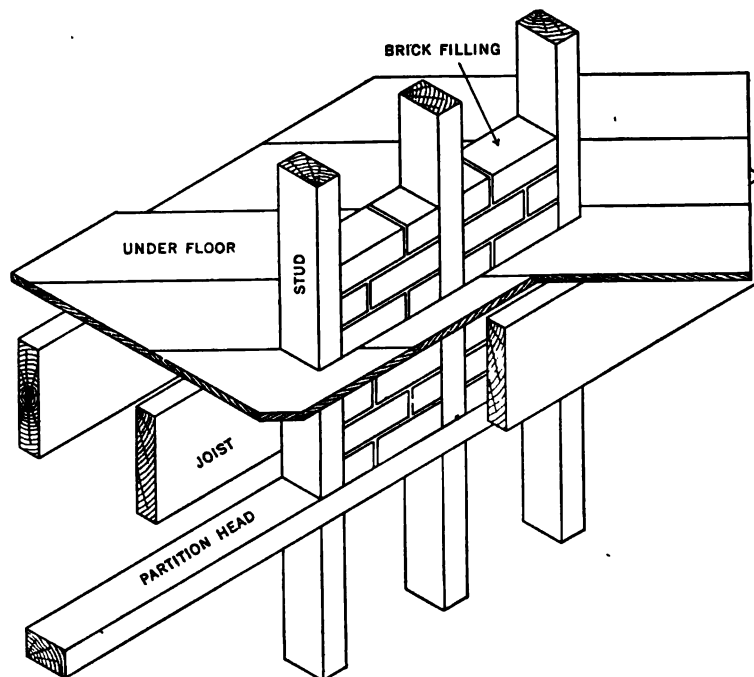

FIG. 35.—Bearing Partition.

the beams are called **rafters**. Rafters are 2" wide, from 6" to 12" deep, and are spaced, generally, 18" or 20" on centers. The rafters meet at the top forming the *ridge*; they meet the wall at the plate forming the *eaves*. *Common rafters* are full length, extending from ridge to plate; *jack rafters* are shorter, running between hips or valleys and the wall plate. All other rafters are designated by the position they occupy in the framework; thus a rafter forming a hip is called a hip rafter; a valley,—valley rafter, etc.

91. Chimneys. As has been stated, the contract for the erection of the complete building may be let to one contractor, who sublets the work to others, or, it may be given by the owner directly to the latter; but in either case they all work in co-operation. The mason, for example, does not wait until the carpenter is all through with

his work; when the latter has set the rafters in place, the mason will have the construction of the chimney well under way, and by the time the roofer begins, the chimney has penetrated the roof.

The New York Building Code requires that, "all chimneys in framed buildings shall be built of brick, or stone, or other fire-proof material. If of brick, the flue shall have walls at least eight inches thick except where flues are lined with burned clay pipe in which case the walls around the flues may be four inches thick." Every fireplace has its own flue. All flues that are in close proximity are brought together, into one chimney stack and carried independently above the roof. A plan

therefore at the top of the chimney will reveal a number of openings, each of which represents a flue of a fireplace in one of the rooms below.

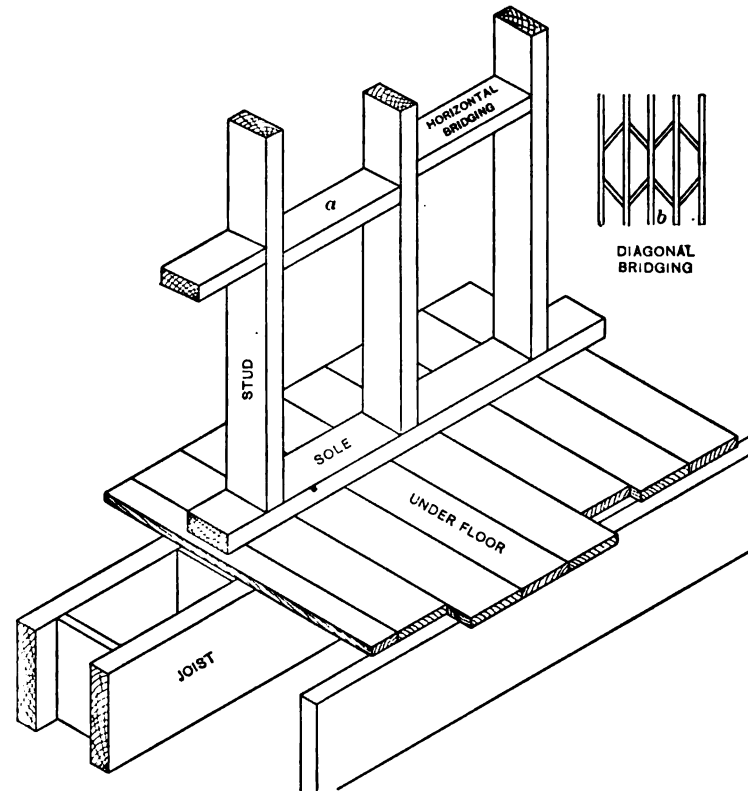

FIG. 36.—Framing of Partitions Parallel with Joists.

Chimneys should be constructed independently so that they are in no way connected with the framework of the rest of the building. Every precaution should be taken to keep all inflammable materials from chimneys.

92. Fireplaces. The usual construction of a fireplace is as follows: The wooden floor beams are framed around the chimney breast by headers and trimmers, and the space left in front of the fireplace is filled in with concrete resting on a "trimmer arch," as shown at *a*, Fig. 37. The concrete is finished off with a layer of cement and the tile or brick set upon the latter.

In addition to being dangerous, a fireplace may

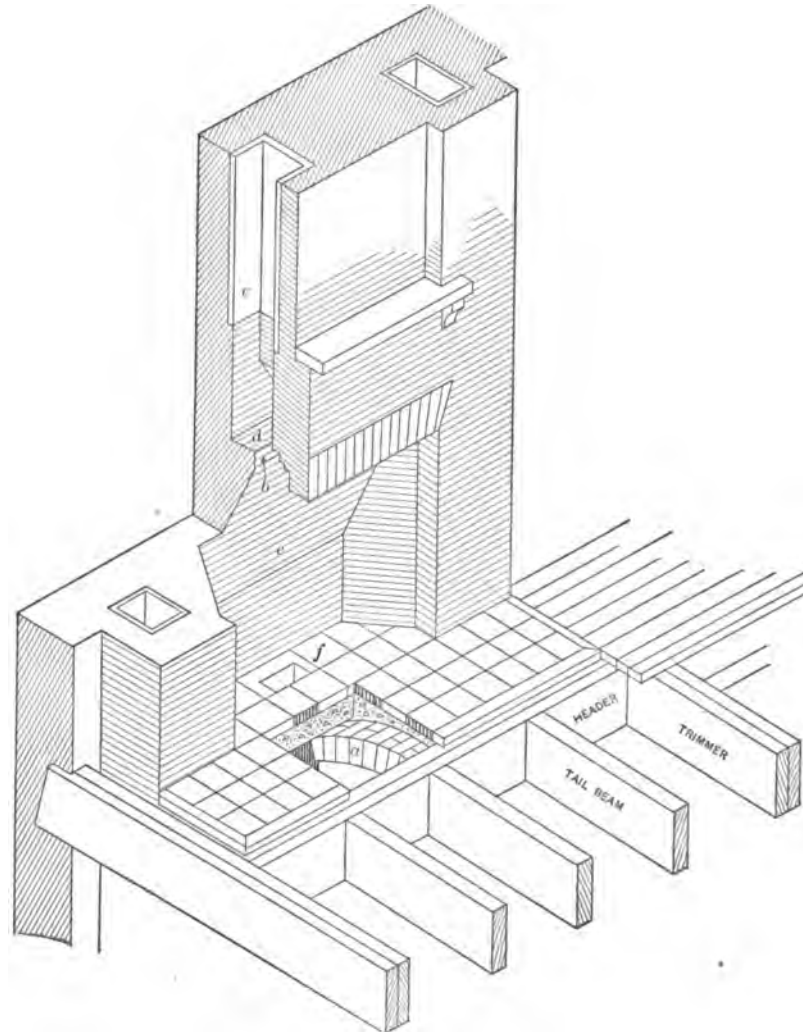

FIG. 37.—Construction of Chimney and Fireplace.

also be a source of extreme annoyance if defectively constructed. The area of the throat (*b*) should be one-tenth that of the fireplace opening. If made narrower or wider the fireplace will smoke. The throat should extend across the entire opening and should gradually contract until it meets the flue (*c*) directly over the center of the fireplace. The flat ledge (*d*) deflects downward currents. Not infrequently, a metal damper is made to slide along the shelf to vary the opening of the throat and regulate the draft. The back of the fireplace (*e*) is inclined forward to deflect more heat into the room. The small opening (*f*) in the rear of the hearth is the ash pit.

93. Exterior Finish. Upon the completion of the house frame the entire outer surface is covered with rough boarding or *sheathing*, $\frac{3}{4}$ " thick, and from 6" to 10" inches wide. There are two ways of applying sheathing, — horizontally, if braces are used at the junction of sill, girt, and plate to corner posts, as in the mortise and tenon frame; and diagonally, if braces are omitted, as in the case of the balloon frame. Diagonal sheathing is by far the better method for it helps to tie the walls of the building firmly together.

94. Finish of Roof. The roof is finished first to protect the building from the weather. The rafters are sheathed, or, as is often the case, covered with laths or *battens*, i.e., strips of wood 2" to 3" wide and from 1" to 1 $\frac{1}{4}$ " thick,

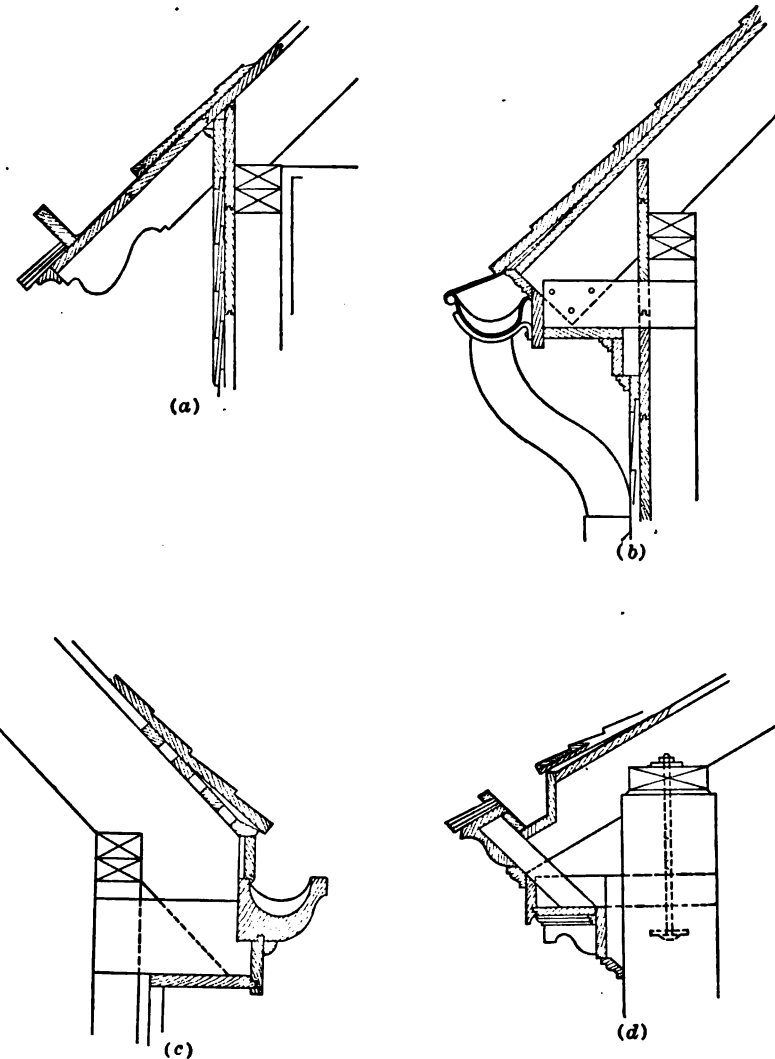

FIG. 38.—Types of Cornices.

spaced so as to afford nailing surface for the slates or shingles. The advantage of using battens is that the direct current of ventilation resulting from their spacing secures against rot in the timbers and the exterior covering.

95. Gutters. The lower ends of rafters are cut to receive the "gutter." Gutters, or "eave-troughs" are worked out of wood, tin, galvanized iron, or copper. They are made in a variety of shapes, the most common being illustrated in Fig. 38. All gutters must be provided with sufficient fall, at least one inch in twenty feet, to allow the water to be carried off to the ground by "leaders" placed at the outlet or lowest point. At least one layer of water-proof paper is secured to the sheathing, or "roof-

boards," before the finishing material—shingle, slate, or tile—is laid.

Gutters form a part of the cornice which is a projection more or less ornamental at the top of a building. There are two types of cornices, the open cornice, Fig. 38(a) and the box cornice, Fig. 38b, c, and d.

96. Shapes of Roofs. There is considerable variety in the shapes of roofs. The shape depends upon climatic conditions, style of architecture employed, and the amount of space required in the attic. In warm countries the roofs are kept low and are given a wide projection to afford shelter from the glare of the sun; while in cold climates where snow and rain are plentiful, the roofs are given a steeper pitch. By *pitch* is meant the angle of

inclination the rafters make with the plate, or the ratio of the rise of a roof to its span. Fig. 39 represents these terms graphically.

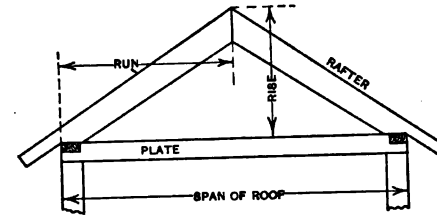

FIG. 39.—Roof Terms.

97. Types of Roofs. Various names are given to roofs according to their form. The simplest form is the roof of but a single pitch—the "lean-to." Of the double pitch form there are four principal varieties: First, *the*

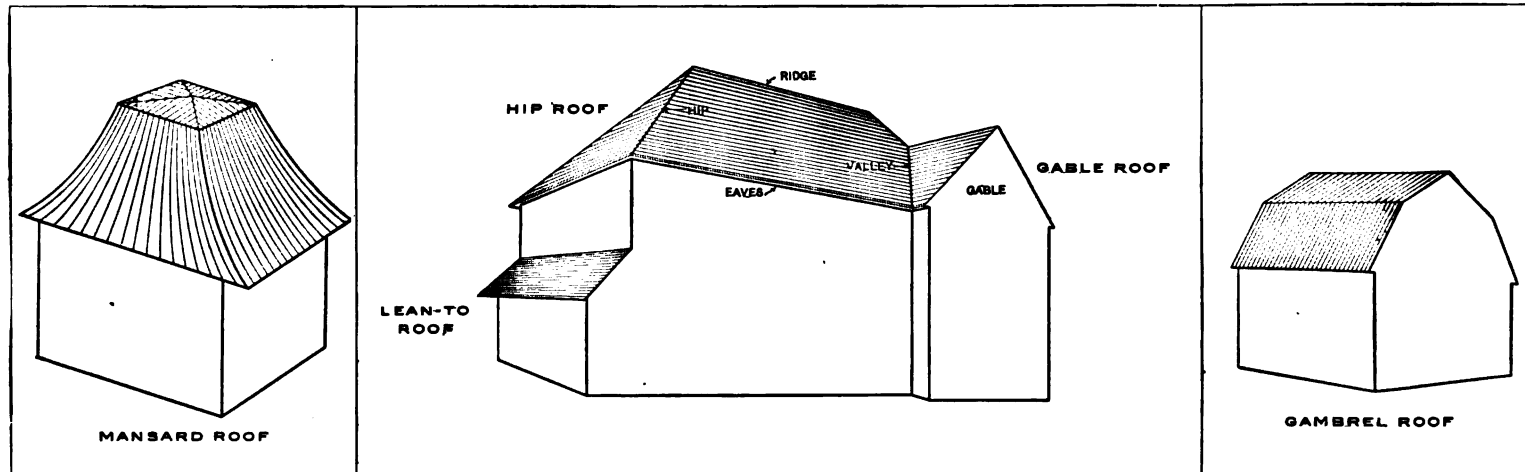

FIG. 40.—Varieties of Roofs.

gable roof, formed by two inclined planes; second, the *hip roof* formed by inclined planes rising from all four sides of the building; third, the *gambrel roof*, formed of two planes of unequal pitch on each side. The last is a roof designed manifestly for the purpose of providing abundant room in the attic. It is an economic form and lends itself readily to artistic variation. Fourth, the *mansard roof* which is a modification of the gambrel, the upper part being of considerably less pitch than the lower. François Mansard, a French architect, was the inventor of this roof. See Fig. 40.

98. Wall Covering. Before putting on the exterior wall finish, *building paper* (felt, quilt, or other insulating material) is nailed, in one or more layers, to the sheathing. Building paper, being of close texture and a non-conductor of heat, renders the building warm in winter and cool in summer.

The materials for finishing in wood the exterior of frame buildings are siding and shingles.

99. Siding. There are two kinds of siding,—beveled and novelty siding; see Fig. 41. **Beveled siding** consists of long narrow boards from 10 to 16 feet in length and from 6 to 8 inches in width, with an inner vertical face and an outer inclined face, showing in section a taper of from one-quarter to one-half an inch. These boards are laid horizontally, overlapping each other, and are exposed about five inches to the weather.

“*Clapboards*” is the New England term for a species of weather-boarding similar in every respect to beveled siding except in length and cut. Clapboards are quarter sawed and come in lengths of four feet.

Novelty siding is the name given to weather-boarding

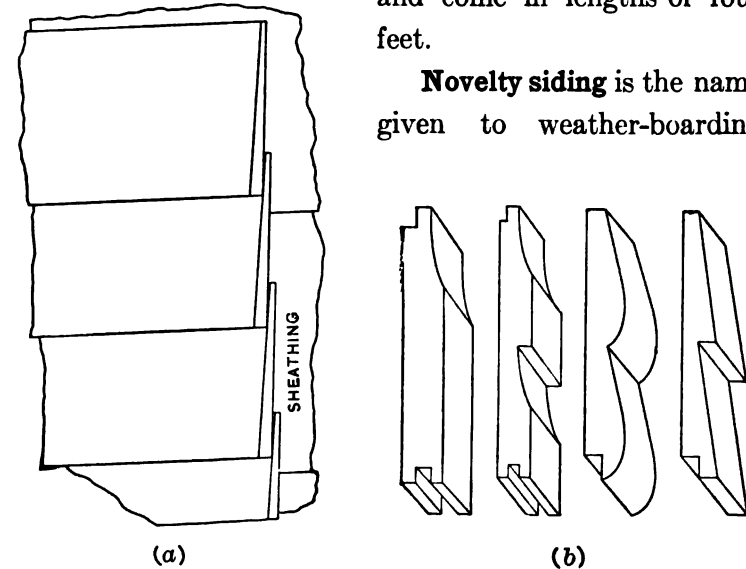

Beveled Siding or Clapboards.

Novelty Siding.

FIG. 41.—Siding.

that has a rabbet or groove cut in the lower edge to receive a corresponding tongue of the board below. This method of uniting siding insures a close joint and accurate alignment in setting. Novelty siding may be molded to any desired shape, the more common styles being illustrated at *b*, Fig. 41.

In the manner of laying and of exposure, the directions given for beveled siding apply to novelty siding.

100. Shingles. These are a very popular covering. Although slightly more expensive than siding or clapboards, the difference is compensated by the enhanced appearance. The ease with which defective shingles may be replaced, and the artistic effects that may be produced by staining and weathering, are important considerations in a wall and roof covering. The alternate dryness and moisture to which the exterior of a house is subjected and the tendency of shingles to buckle and warp are conditions to be considered in their selection. They should not exceed six inches in width, or be greater than sixteen inches in length. Their thickness is designated by the trade term "5-2," which means that the butts of five shingles placed together will measure two inches. In laying shingles care should be taken that the joints are broken. Shingles are exposed $4\frac{1}{2}$ inches to the weather on roofs, and 5 inches on walls. See *b*, Fig. 42.

101. Corner Boards. Water Table. If siding is used as the finishing material, provision must be made for the junction of the boards at the corners, and for the connection of the frame wall with the brick or stone foundation. The first condition is met by using boards about six inches in width, laid vertically at the corners, for the siding to butt against; see Fig. 42(*a*). Corner boards may

be dispensed with if the siding is mitred at the corners. To overcome the second difficulty, namely, the union of frame walls and masonry foundation walls, requires the construction of a *water table*.* The sloping member, *x*, Fig. 42, keeps the water away from the foundation; flashing (*y*) is introduced to make the joint between the frame wall and water table air and water-tight.

When shingles are used as an exterior covering, those at the corners are mitred, thus doing away with the necessity for corner boards; nor is any special construction required for the water table. The row of shingles nearest the foundation is tripled and given the necessary projection by inserting furring blocks, as shown in Fig. 42(*b*).

102. Flashing. Flashings are small pieces of tin, zinc, or copper placed at all joints in a building where leaks are liable to occur. The principal places requiring flashings are around the openings in the roof for the chimney, skylight, or dormer, and over doors, windows, and water tables.

103. Stucco. Plaster applied externally, is a form of finish that is being used extensively for suburban and country residences. Its popularity may be attributed first, to its availability as a surface covering for every kind of house, regardless of the material entering into the construction, and second, to the varied and artistic effects that may be easily obtained.

* Water table.

When stucco is applied to a frame building, expanded metal lath or wire cloth is preferable to wood laths owing to its fire-proof qualities and the firm clinch or key it affords to the plaster. The wood laths absorb the moisture

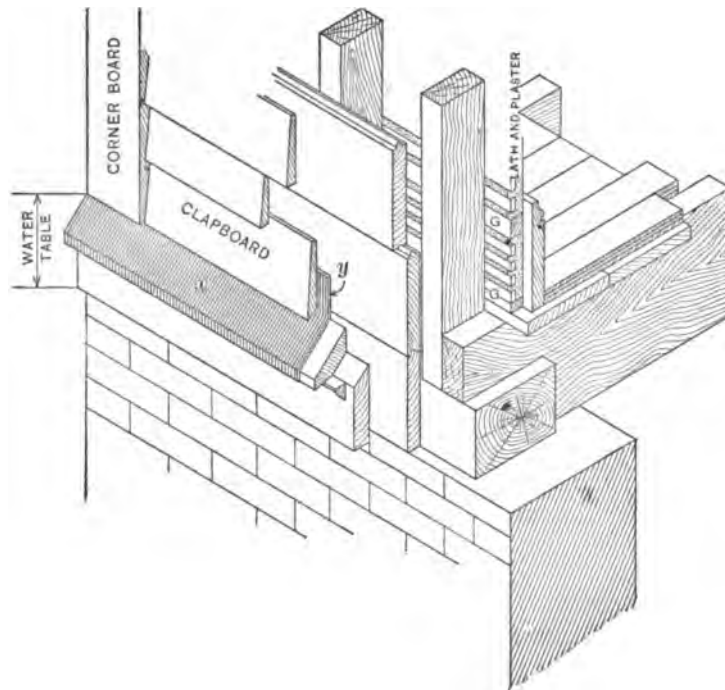

Showing Treatment of Corner when Clapboards are used.

required by the mortar and when they dry and shrink cause the plaster to crack and eventually to break off.

Metal lath should be galvanized or painted to prevent rusting. Wood laths should be one inch wide and should

be set about $\frac{3}{4}$ inch apart. Fig. 43 is a vertical section through a wooden wall showing the manner of attaching metal lath both inside and outside. Wood laths are similarly applied. Vertical strips of wood, called *furring strips*, 2

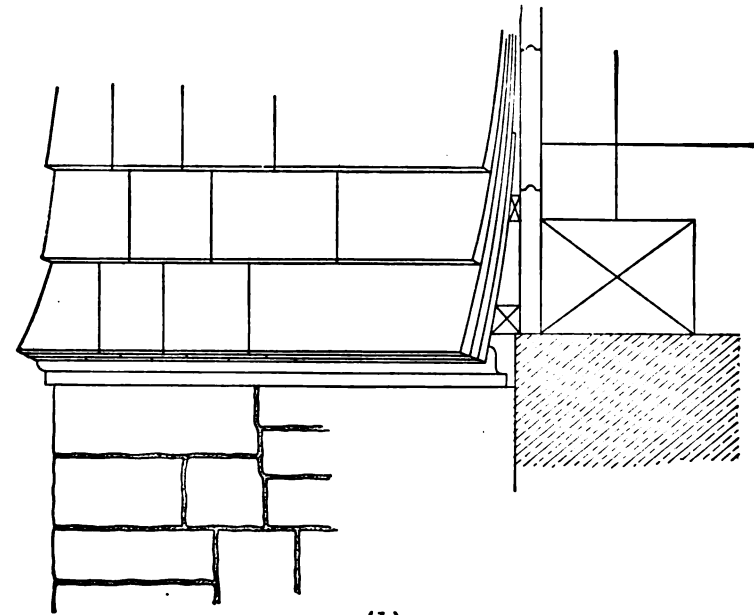

(b)

Showing Treatment of Corner when Shingles are used.

FIG. 42.—Water Tables.

inches wide and from $\frac{3}{8}$ inch to $\frac{7}{8}$ inch thick, set about 9 inches on centers, are nailed to the outside boarding which has been previously covered with water-proof felt. The lath is then attached to the furring strips and the plaster is put on.

Some of the finishes that may be obtained in stucco work are shown in Fig. 44.

Stucco is sometimes referred to as cement plaster because it is invariably composed of Portland cement and sand.

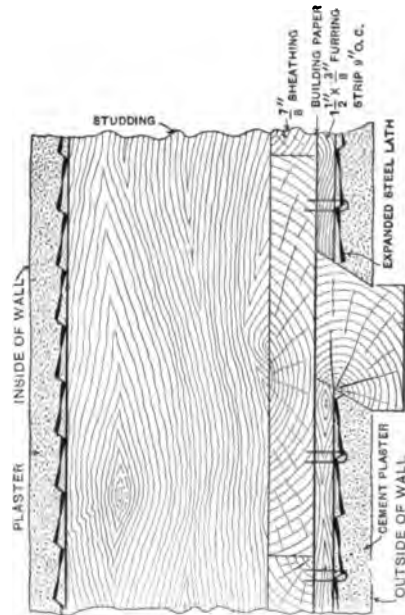
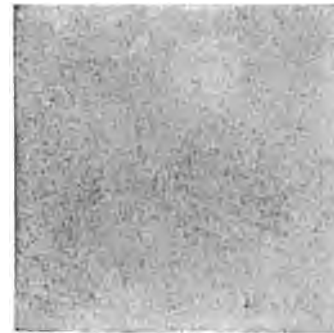

FIG. 43.—Section through a Frame Wall with Stucco Finish.

104. Veneered Walls. Walls that have a backing of one material, such as wood or hollow tile blocks, and a facing of another material, such as brick, are said to be veneered. Frame walls with a veneer of brick or any other masonry material are more substantial, more attractive in appearance, and possess greater fire resisting

qualities than walls built entirely of wood. In Fig. 45 are shown two forms of masonry veneer. The method of anchoring the veneer is the same in all cases. Galvanized



Sand Finish.



Sand Finish Stippled.

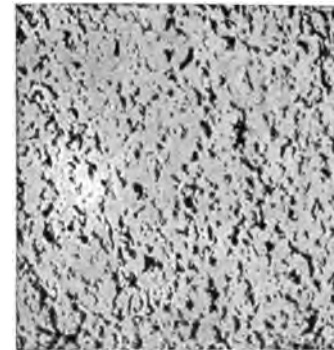

Rough Cast.

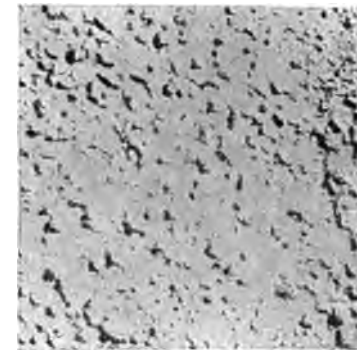

Pebble Dash.

FIG. 44.—Different kinds of Stucco Finish.

iron wall ties, several types of which are illustrated, are spiked at one end to the sheathing, the other end extending into the mortar joint.

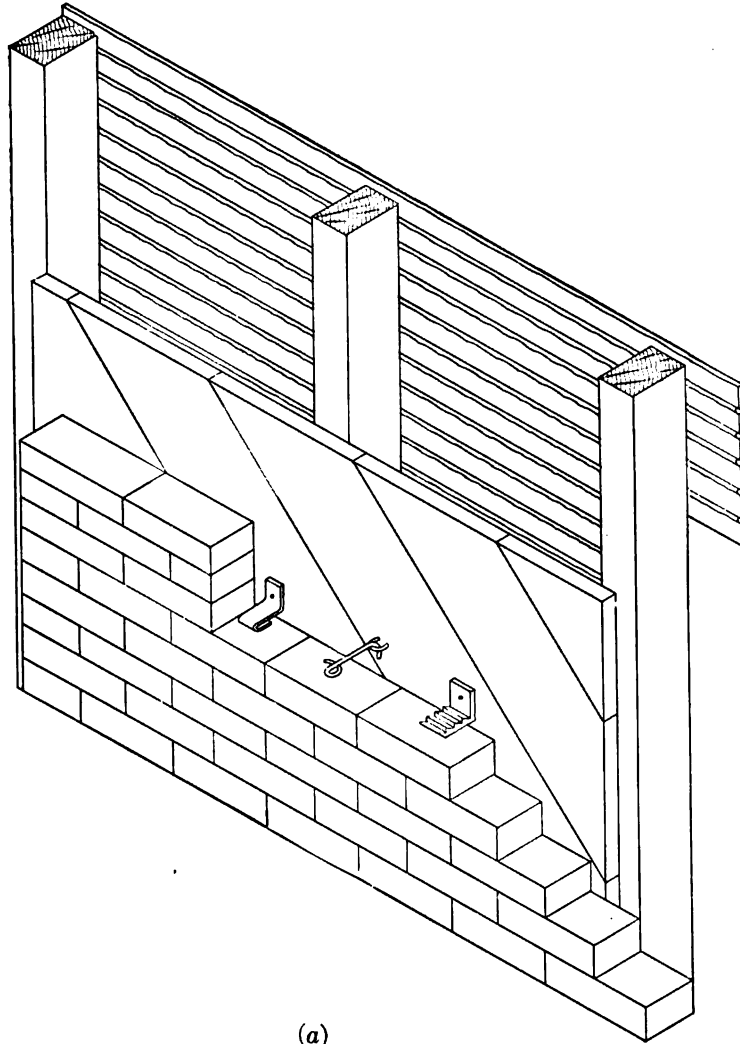

(a)
Brick Veneer.

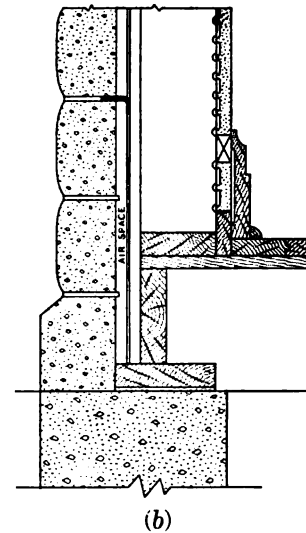

(b)
Cement Block Veneer.

FIG. 45.—Veneer Construction.

In laying veneer, as brick, for example, it is most important that an air space of about one inch should be left between the back of the brick and the inner face of the weather-boarding. The air space, as previously explained retards the passage of moisture and is a most efficient insulator of heat. A brick veneer house is not very much cheaper than one built of solid brick; and unless there is an air space the veneer system of construction loses two of its chief advantages, namely, warmth and dryness.

105. Windows. As a preparation for the installation of the windows, the studs around the openings are doubled; a simple truss is placed overhead, if needed; the sheathing is cut away; and the building paper is well lapped and tacked; everything is then ready for the insertion of the window.

A window consists of two parts—the sash and the frame. The sash holds the glass, and the frame holds the sash. In the manner of fixing the sash, windows are classified as *double-hung* and *casement*. There are so many variations of both types, however, that their treatment must be limited to the principal

features of each and to discussing some of the most common forms.

The double-hung window consists of two sashes, each extending one-half the length of the opening. Each sash is suspended by cords passing over pulleys and counter-balanced by weights. This arrangement facilitates opening and closing. The most common form of double hung window is rectangular in shape, as shown at (A), Plate XI. Semicircular and segmental heads are popular modifications of this style. The usual treatment of the latter class of windows is shown at (C). Where the openings are too large for single windows, or where the artistic features demand an increase in the number of windows, they are grouped as at (B); not infrequently three and four windows being combined under one frame. When thus united the vertical divisions between the adjacent pairs of sashes are called *mullions*.

Casement windows, shown at (E), also have two sashes but they are divided vertically and hinged at the sides thus opening like a door. Casement windows usually have two distinct divisions; the lower and larger division being occupied by the hinged sashes and the upper division by a much smaller sash, fixed or pivoted, called a *transom*.

French windows are casement windows extending down to the floor. Both types of windows should be made to swing in instead of out; this insures their being water-tight.

A dormer window is a vertical window, double hung or casement, projecting from a sloping roof. Aside from the function of lighting rooms in the attic, the dormer window plays an important part in the design of the structure.

Dormers may rest entirely upon the roof, as (F), or, they may be a continuation of the wall of the building, extending a short distance above the eaves, as shown at (G).

Bay windows, as (D), are windows projecting beyond the face of the wall. They are circular, polygonal, or rectangular in plan and extend one or more stories in height.

As in the case of dormer windows great care should be taken in the design of bay windows for they can make or mar a successful design. They should not be applied to the surface of the wall merely, but should be wrought into it and made to form an integral part of the composition.

106. Doors. Doors are either solid or veneered. Solid doors are made of white pine, cypress or whitewood. Veneered doors are made by building up cores of narrow strips of seasoned white pine placed with the grains reversed, glued and held together under enormous pressure until dry. The face or surface veneers are then glued on to the core, the grain of the former being set at right angles to that

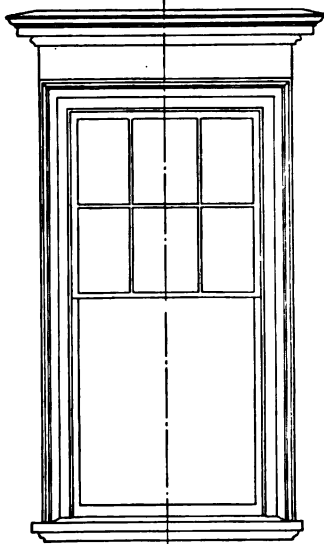

(A)

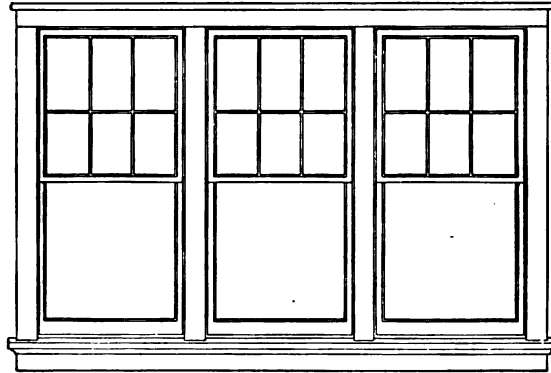

(B)

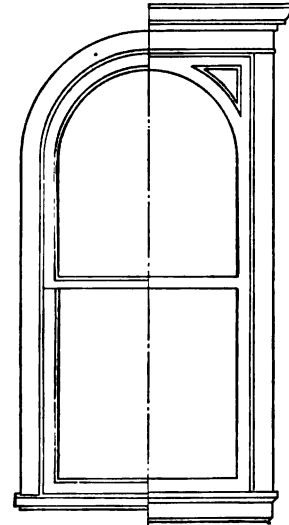

(C)

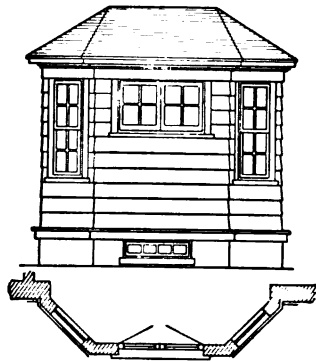

(D)

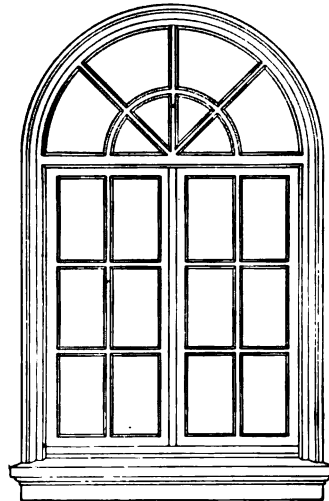

(E)

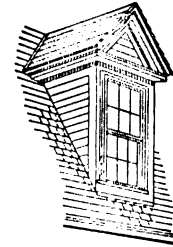

(F)



(G)

of the latter. All the parts are then subjected to a powerful hydraulic pressure, thus insuring a door more substantial than one made of solid wood, and also one that will not warp. Veneered doors, as compared with solid doors, keep their shape remarkably well, for every precaution is taken in their construction to eliminate swelling and shrinking. The "rotary" cut is the only method of making veneers which will show to advantage the beautiful rich grain of ash, mahogany, birch, and oak.

Doors are distinguished by their mode of construction. The three principal forms are:

(a) The **ledged door**, which is the simplest and cheapest kind, consisting of vertical battens or boards nailed to horizontal pieces of timber called ledges, see (A), Plate XII.

(b) The **ledged and braced door**, which is a ledged door reinforced with diagonal braces as shown at (B). (The exterior of these doors presents the same appearance.)

(c) **Paneled doors**, which consist of a framework of timbers mortised and tenoned together and grooved to receive thin boards called panels. These panels should be set loose as shown in Fig. 46, to prevent their splitting from contraction and expansion. Paneled doors are made in an infinite variety of designs. They cover a wide range of sizes the most common being 2' 8" × 6' 8" or 2' 10" × 6' 10" for interior doors (except closet doors which

are 2' 6" × 6' 6") and 3' 0" × 7' 0" for exterior doors. The thickness of doors is usually 1 $\frac{3}{8}$ " or 1 $\frac{1}{2}$ ". Several examples of interior and exterior paneled doors are illustrated in Plate XII.

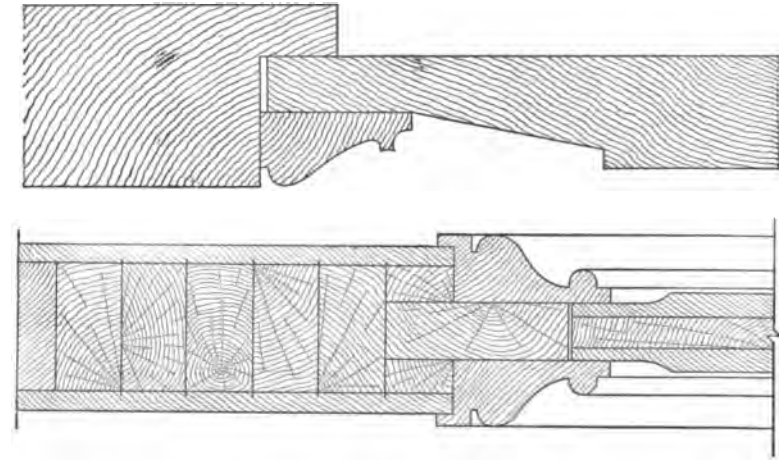
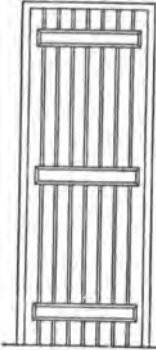

FIG. 46.—Construction of Wood Panels for Doors.

107. Interior Finish. For obvious reasons, the interior finish is delayed until the roof is completely set up and the sheathing nailed in place. The first work to be done on the interior is to put on the lath for the plastering.

Wood laths vary slightly in thickness and width, the most common size being $\frac{3}{8}$ " × 1 $\frac{1}{2}$ ". They are 4 feet in length and are set $\frac{1}{4}$ " apart. The plaster is squeezed through these spaces and, on hardening, forms a strong clinch or *key*. Laths should never run vertically nor

A.-
LEDGED
DOOR



INSIDE

B.-
LEDGED
AND
BRACED
DOOR

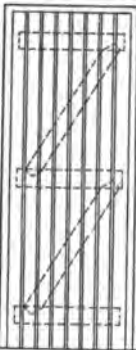

OUTSIDE
OF A & B

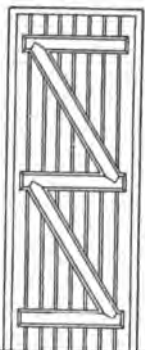

INSIDE

C.-
PANELED DOORS

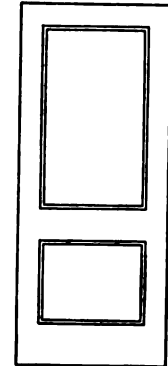
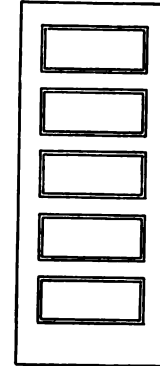
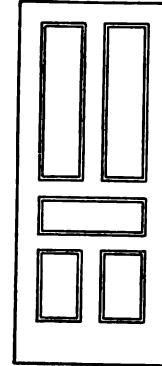
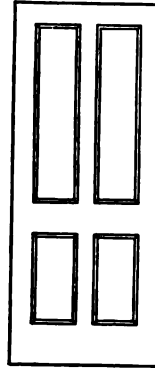

1'- INTERIOR DOORS

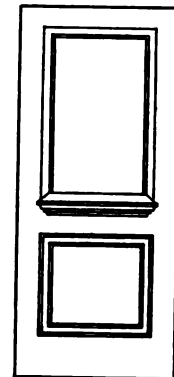
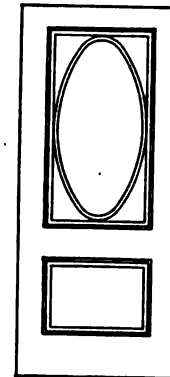
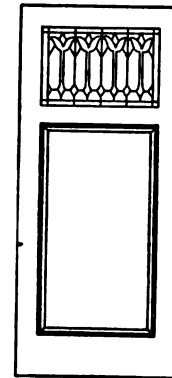
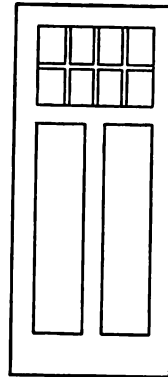
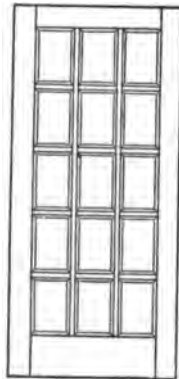
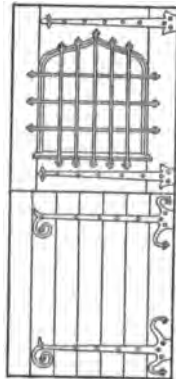
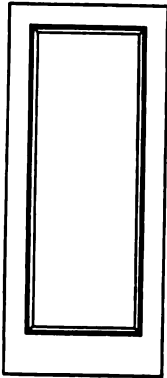

2'- EXTERIOR DOORS

should they pass from one room to another across a partition. They should be nailed to every stud or beam, the joints being broken at least every tenth lath.

The stringent building ordinances in regard to fire-proofing of particular structures have brought about the introduction of metal lath. The advantages of metal over wood lath have been discussed in Article 103.

Grounds. Plaster must be stopped around all openings. This is accomplished by means of long, narrow pieces of wood called "grounds." They are 2" wide and $\frac{3}{8}$ " thick for two-coat work and $\frac{3}{4}$ " for three-coat work. Grounds must be absolutely plumb and true for they act as guides to the plasterers in obtaining a flat, even surface. Grounds also act as supports for nailing such interior finishing work as architraves, cornices, baseboards, etc.

Plaster. Interior plaster is composed of thoroughly slaked lime mixed with hair, sand, and plaster of Paris in varying proportions. Plaster is applied in layers or coats, —either two or three coats. The first is called the *scratch coat*; the second, the *brown coat*; and the third, the *skim* or *finish coat*. No coat should be applied before the preceding one is absolutely dry. The total thickness including the lath is $\frac{3}{4}$ " for three-coat and $\frac{3}{8}$ " for two-coat work.

Ornamental plastered work not infrequently has wide

projections, as for example, cornices, false beams, and the like. As plaster should nowhere be more than one inch thick a false construction called "furring" must be used. Furring consists of small pieces of wood attached to framing members, and roughly cut to the required shape

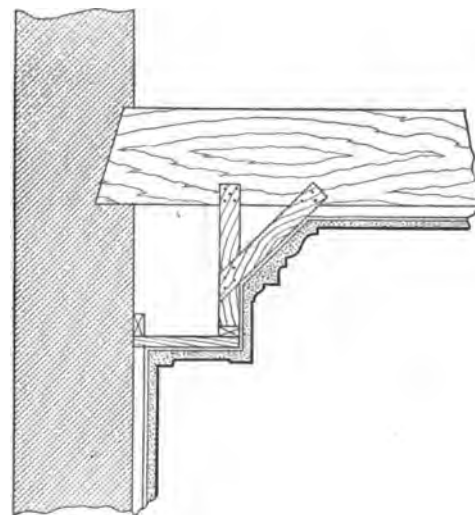

FIG. 47.—Furring for False Beam.

of the surface to be finished, as shown in Fig. 47. When metal lath is used it may be attached to wooden furring, if the building laws permit, or to metal tees, angles, or channels.

108. Standing Finish or Trim. Plain plastered walls would be dull and uninteresting. For that reason and also

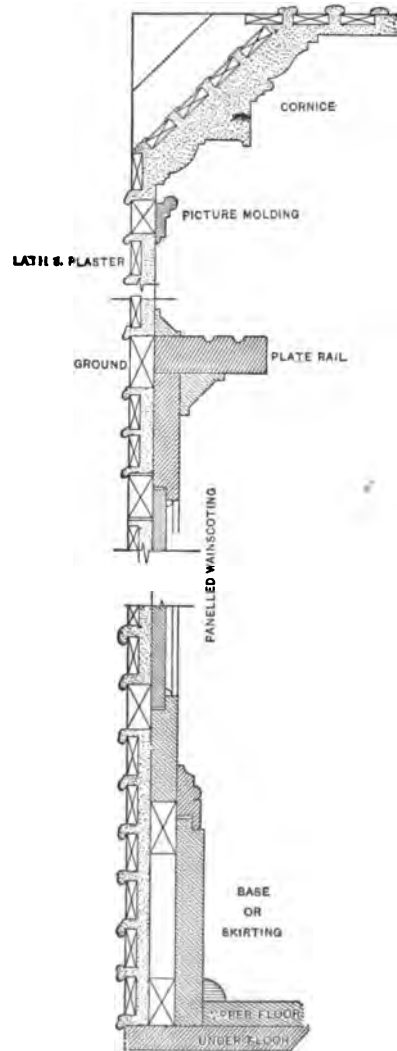

FIG. 48.—Interior Trim.

for very practical considerations, soon to be described, architectural members are introduced in the interior.

Outside the plastered wall, where it meets the floor, a board 8" or 10" in width and known as a **base-board**, see Fig. 48, is run around the entire room. It protects the plaster from injury, conceals the line of contact between floor and wall, and gives an architectural finish to the room.

Parallel to the base and above it, at a height to receive the back of a chair, a molding of simple profile, called a **chair-rail** is sometimes placed around the room. It is usually found in dining-rooms and halls.

Not infrequently the base and chair-rail are combined into a **wainscot**, in which case the entire lower part of the wall to a height of from 3 to 5 feet, and even higher, is covered with panelling. In a hall the top of a wainscot may serve the purpose of a chair-rail, and in dining-room and den, of a *plate rack*, as illustrated. Tile is, for sanitary reasons, the most practical material for a wainscot, in the kitchen, laundry, and bathroom, although more expensive than wood.

"When wood wainscoting is used, the surface of the wall or partition behind such wainscoting shall be plastered down to the floor line, and intervening space between the said plastering and wainscoting shall be filled in solid with incombustible material" (N. Y. Building Laws).

Architraves are moldings, more or less ornamental, fixed around door and window openings to conceal the joint between the rough frame and the plastered wall.

The **cornice** is the crowning member of the interior decorative scheme of a room. It may be made of plaster, wood, or metal, in an infinite variety of designs. Very often the picture mold is worked into the design of the cornice.

109. Floors. In good construction, two thicknesses of flooring are used; the under or rough floor, consisting of tongued and grooved boards, laid diagonally over the joists, and the finished floor laid over it at right angles to

the joists. A layer of heavy, damp-proof paper or deadening felt, separates the two floors.

The underfloor bears the same relation to the joists that sheathing does to the exterior frame; it binds and strengthens the floor beams by checking any tendency to warp. Moreover, as the rough floor boards are nailed in place simultaneously with the erection of the framework, they serve as a platform for the workmen during the construction of the building. Underflooring is $\frac{3}{8}$ " thick and should not be more than 6" in width, to prevent warping.

For obvious reasons the finished floor boards are not laid until the plaster is dry and the standing trim—base-board, chair-rail, etc,—is in place. Finished flooring

varies in thickness from $\frac{3}{8}$ " to $\frac{7}{8}$ " and in width from $1\frac{1}{4}$ " to $3\frac{1}{2}$ ". Several of the more common methods of jointing these floor boards are shown in Fig. 49. Flooring should always be "blind nailed."

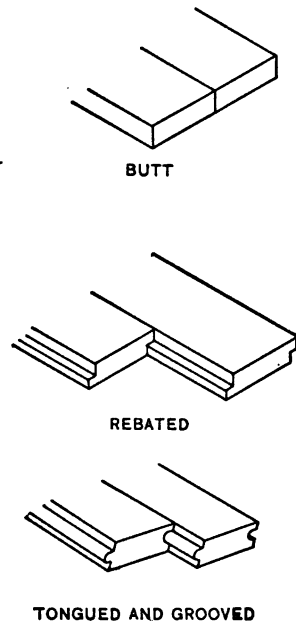

FIG. 49.—Flooring.

110. Stairs. Stair building is so wide in scope and so complicated in construction that it is usually left to one who has made a specialty of the subject, the stair builder. A comprehensive treatment is not within the scope of this text and it is therefore limited to a description of the most important terms used in connection with stair building, and the general methods of planning and construction.

Definitions. *Staircase* is a term used to designate the entire system of stair communication. *Stairway* is the space set apart for receiving the staircase. The *stairwell* is the opening in the ceiling to permit passage from one floor to another. A *flight of stairs* is an unbroken series of steps leading from one story to the next. The *rise* of a flight of stairs is the vertical distance from the top of one floor to the top of the next; while the *run* denotes the horizontal distance from the face of the first vertical member, or "riser," of a step to the face of the last riser in the same *flight*. The horizontal member of a step is called the *tread*. A tread is composed of two parts,—the *run* which is the distance from the face of one riser to the face of the next and the *nosing* which is that part of the tread extending beyond the face of the riser, including any molding that may be placed underneath. *Winders* are steps triangular in shape and are frequently required in turning corners. Their use is recommended for dwell-

ings only and even there should be used sparingly, for one may easily trip over them.

As a matter of convenience and safety small upright posts, or *balusters*, supporting a *handrail*, are placed at the outer end of the stairs. Handrails are molded to a section easily grasped by a person going up or down the stairs.

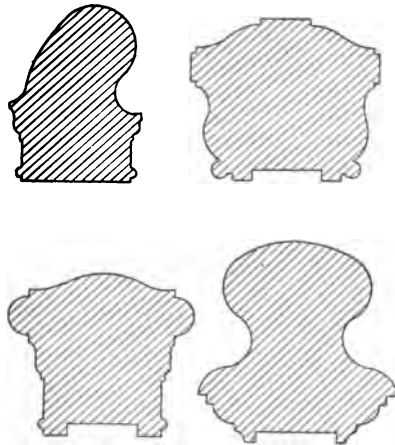

FIG. 50.—Section of Handrails.

Fig. 50 presents sections of handrails most frequently seen. *Newels* are posts more ornamental and of larger dimensions than balusters, set at top, bottom, and turns of stairs to receive handrails; they also help to support the "strings." *Strings* are inclined timbers supporting the steps.

Classification. The simplest manner of arranging stairs is shown at (A), Fig. 51. It is known as a *straight run*. A flight of stairs enclosed between two walls is known as *box stairs* (B); this is the cheapest form of stairs. As a straight stair requires more space than is usually available, *dog-legged stairs*, (C), are sometimes adopted. These, on the other hand, go to the opposite extreme, and crowd

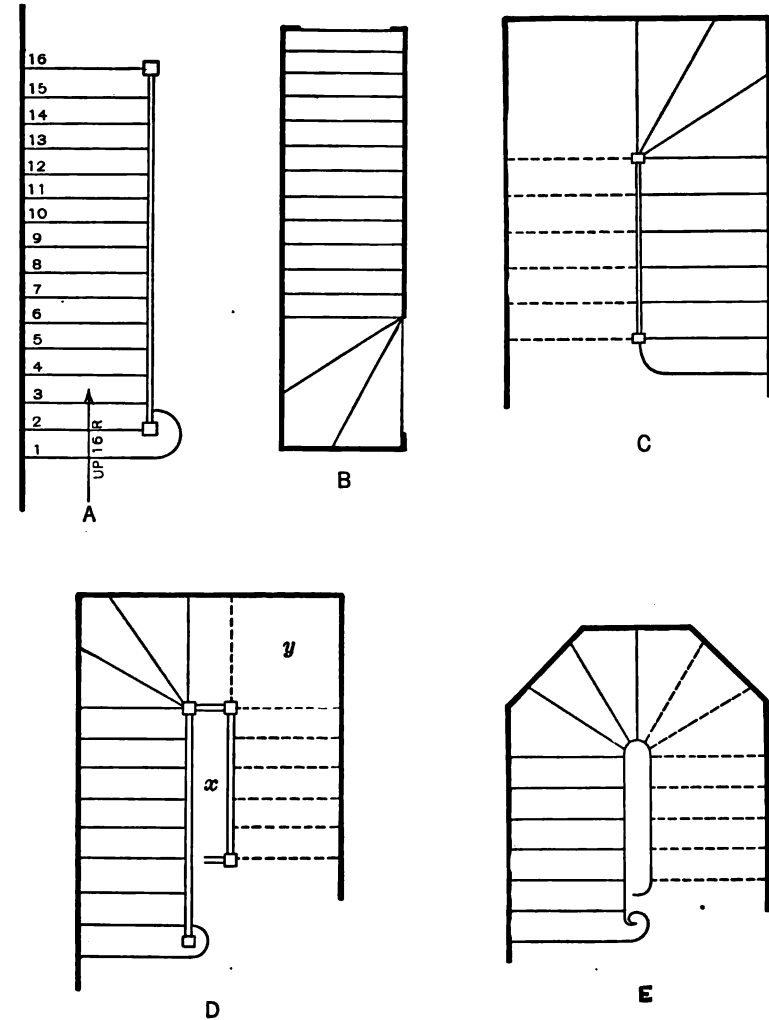

FIG. 51.—Types of Stairs.

a maximum number of steps into a minimum amount of space. They consist of two parallel flights so arranged that the outer or face string and handrail of the lower flight come in the same vertical plane as the face string and handrail of the flight above. Winders and risers of uncomfortable shape and size must often be used to crowd the requisite number of steps into the small area and, therefore, dog-legged stairs are relegated to the rear of the house. At (D) is shown a plan of an *open-newel stair*, the distinguishing features of which are the well hole (x), and the landing (y). Although encroaching upon valuable space, they justify themselves by enhancing the appearance of the entire staircase and yielding a great deal of light and comfort. A *geometrical stair* (E) is the highest type of stair and is constructed without newels at the turning points.

Lay Out. In setting out stairs, the first point to be con-

sidered is the height from floor to floor, which in this case, Fig. 52, is 9' 6". To find the number of risers the total height, must be divided by the height of the riser, which

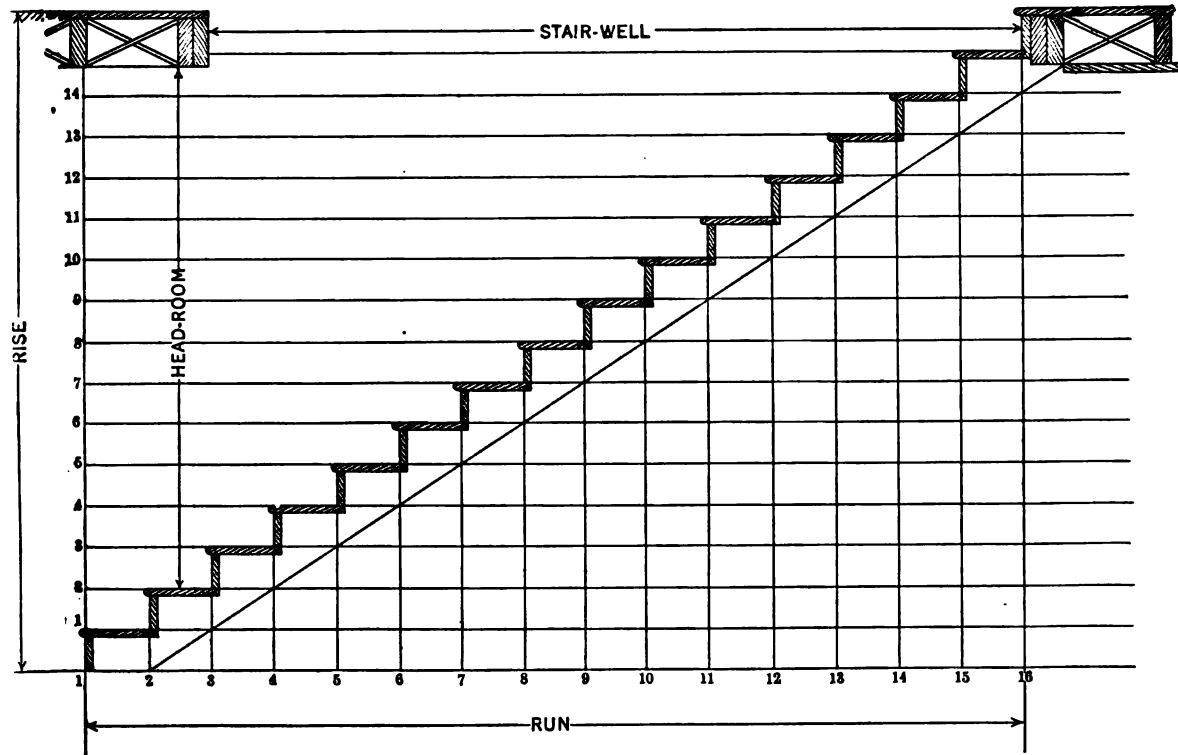

FIG. 52.—Stair Arrangement.

is assumed to be 7"; the quotient, $16\frac{2}{3}$, will be the number of risers required. But as all risers must be of the same height, it will be necessary to change the height of the riser

either to $7\frac{1}{8}$ " or $6\frac{1}{2}$ ", obtaining respectively 16 or 17 risers. To determine the width of the tread, apply the following rule:

Rise \times run should not exceed 75 nor be less than 70.

Experience has shown this to give the most comfortable tread. Accordingly, in our case, we may adopt a 10" or $10\frac{1}{2}$ " tread. To obtain the run of the stairs multiply the width of a tread by the number of risers less one. *Headroom*, that is, the vertical distance from the underside of the face of the trimmer above to the tread of the step directly below, should be 7' 0". This distance not only gives ample clearance for a tall person but also permits furniture to be moved from one floor to another without injuring the plastered walls.

In laying out stairs care should be taken to have the outer face of the riser adjacent to the newel post come directly in the center of its base. The direction of the stairs, whether up or down and the number of risers from one floor to the next should be indicated on the plan; see (A), Fig. 51

Construction. At (A), Fig. 53, is shown the most practical method of joining treads and risers, and of securing balusters. When the ends of steps are exposed to view, the face string is notched to receive the treads and risers as shown at (B). A string thus cut is known as an *open string*. A *closed string* (C) is one that is employed in constructing steps the ends of which are hidden from view. In this type, trenches, (x), are cut into the string, and

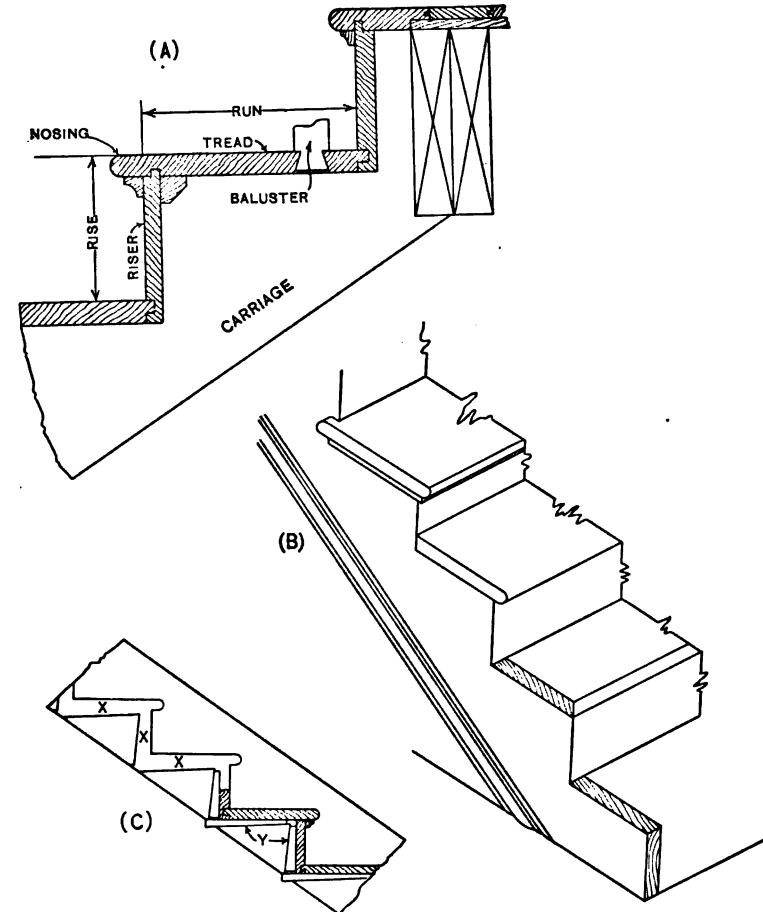

FIG. 53.—Details of Stair Construction.

they are made large enough to allow for the insertion of small tapering wedges, (y), which are glued and driven in place after the treads and risers have been set.

SECTION VI

DESIGN

111. Utility. Architecture is a harmonious combination in a structure of utility and beauty. By utility is meant the function, or purpose, of a building. The uses to which buildings are put are many and varied, and the considerations to be taken into account in their planning, are therefore manifold and complex. Thus, a hospital must be so planned as to give each chamber not only a maximum amount of air space and sunlight, but also automatic heating and ventilating apparatus must be installed to maintain a uniform temperature. Every detail must be so constructed as to insure sanitation; windows in the surgical quarters must be suitably arranged; devices must be provided to deaden or eliminate all noise; especially fitted quarters must be constructed for contagious diseases; every ward must have its particular equipment.

In the design of a hotel, skill and ingenuity must be exercised in confining in the engine rooms, scarcely exceeding ten per cent of the cellar floor area, the hydraulic and pneumatic machinery, electric generators, engines, heating,

lighting and ventilating apparatus, and machinery for elevators. The same complexity of conditions exists in school buildings, churches, etc. The detail of the utility of a design is too vast a subject to be taken up in this brief and elementary treatise.

112. Beauty. In the consideration of beauty, we encounter entirely different conditions. Beauty cannot be defined; it is an elusive principle, but its manifestations are apparent and readily recognized. Any monument, whatever its function, must conform to one or more of the architectural laws of beauty. An examination of the greatest achievements in the field of architecture will reveal definite methods of procedure,—certain ideals which the architects tried to achieve, and certain principles that guided them in all their work.

Every architectural classic has its variable and invariable elements. The variable attributes of a design are temporary and local in character. They are particular and individual in that they are the traits of a single building. The invariable attributes are universal and common to the

masterpieces of all ages. They are the "permanent residuum" of architecture. What these eternal features, these principles of architectural design are, we shall endeavor to set forth.

"Laws and rules," says Helmholtz, "on whose fulfillment beauty depends, are not consciously present in the mind of the artist who creates the work or of the observer who contemplates it." Nevertheless, these rules are followed either consciously or unconsciously by every master designer.

113. Factors in Design. Design in architecture is a pleasing disposition of parts. Among the factors that contribute toward evolving designs of character are *expression, proportion, fenestration* and *decoration*.

114. Expression. Expression in sculpture and painting is easy to comprehend. But expression in architecture cannot be made to convey the same ideas or sentiments, for it has neither the susceptibility of painting nor the plasticity of sculpture. On the other hand, architecture may express the emotions of the designer, the impulses and ambitions of the nation as well as of the individual. The triumphal arches of the Romans express the warlike character of the people. The Parthenon expresses to the highest degree the refinement and grace of the Greeks. The furniture designed during the reign of Louis the Fifteenth portrays the degradation of its times. Cathedrals

are made lofty, for they thus express most admirably our spiritual sentiments.

Every building of distinction bears the impress of the personality of the designer. Bernini's works, Palladino's, Wren's, and H. H. Richardson's, are easily distinguished because of their intense individuality. Master designers put their souls into their work, making the final structures as easily recognizable as if their authors' names were chiseled in every brick and stone.

But far more important is the expression in a building of its plan, its interior arrangement, and its purpose. The expression of function is of primary importance. As has been intimated in the early part of this work, every building must give some suggestion of life. Architecture "speaks a various language" that all who see it may know its purpose; its evidence must be *prima facie*. A structure should be built obviously and naturally for the purpose for which it was intended. This is done by properly recognizing and frankly exhibiting on the exterior its internal organism. In some buildings, the very necessities of the structure constitute unmistakable expressions of purpose, as for example, libraries, railroad stations and armories. In all buildings, whether the function is evident or not, structural lines should be emphasized not concealed, and all sham and pretense should be eliminated. We should strive for truth and sincerity in architectural expression.

115. Proportion. By proportion is meant harmony in the relations of the parts of a structure. To be in good proportion, a composition must be so divided as to produce a pleasing relation of one part to another and of each to the whole. Since a well designed building is one in which there is proportion of masses, proportion of details, and proportion of details to masses, it follows that the simpler the design, the less adjustment will have to be made. The beauty of the Greek Parthenon is of a far higher type than that of Notre Dame, because the perfect proportions of the Parthenon are seen at a glance, while in Notre Dame the relation of space and mass are more subtle and its divisions are so numerous that its refinement and excellent proportion reveal themselves only after very close observation and prolonged study.

To obtain good proportion, emphasize the principal masses and subordinate the subsidiary masses. That element in a composition which is of most importance should dominate both in size and position. No definite rules, however, can be formulated. Practice, observation, and good taste are the only guides and means whereby a pleasing relation of parts in a composition can be secured.

Many attempts have been made to reduce proportion to a scientific basis. One individual went so far as to solve the entire, complex problem by means of a mathematical formula; another by a geometrical figure. But these men

lost sight of the fact that architecture is an art as well as a science.

Vignola (1507–1573), after making an exhaustive study of the proportions of the classic monuments, wrote a book on the five orders of architecture. This treatise, however, should not be construed as an attempt to reduce architecture to a mechanical or mathematical basis. It simply sets forth the proportions of the finest examples of Greek and Roman structures. Vignola's proportions of the orders have become standard.

The term *order* denotes the column and the entablature. The Greeks to whom must be given the credit of originating the modern columnar system of design, used and developed to a high degree of perfection three orders only; viz., Doric, Ionic, and Corinthian. The Roman orders—Tuscan, Doric, Ionic, and Corinthian—are a simplification of the Greek orders, and although not so refined and beautiful, are much more practical and more easily executed.

Greek moldings are conic in section; they are composed of curves of the parabola, hyperbola, and ellipse. Roman moldings are made of arcs of circles and can, therefore, be struck with a compass.

116. Fenestration. A pleasing arrangement of voids and solids is an essential and ever present feature of all good design. Voids are meant to include windows, doors, arch-openings, etc. Solids refer to the wall surfaces between

the voids. The allotment and distribution of voids and solids are regulated by climatic conditions, the size of the rooms, and the uses to which the rooms are to be put.

In warm countries the windows are made small to keep out the glare of the sun.

Large rooms should have large openings, small rooms, small openings. There should be no false suggestion on the outside concerning the interior arrangement. Deception in design should be condemned, for it is not good architecture.

The function of a building also determines the character of fenestration. A prison, for example, should have small windows placed close to the ceiling. Stores should have large window spaces to admit of the appropriate display of merchandise.

Openings should come directly over one another; piers should be superimposed and should rest directly on the ground, never over a void. The wall surfaces at both ends of a building should be made wider than the intermediate surfaces. If columns or pilasters are used at the ends of the wall, they should be doubled. These practices tend not only to give the building an appearance of strength and security, but they satisfy æsthetic demands in that they break the monotony of repetition of the same *motif*, call a natural stop and afford a resting place for the eye.

A more pleasing effect is produced if windows are grouped

vertically in an odd number of rows instead of in an even number. That is to say, if windows are superimposed, three or five rows would look better than four or six rows. As a general rule doorways and windows are made twice as high as they are wide.

The basis for all these practices is simply the result of experience and good taste.

GENERAL MAXIMS IN FENESTRATION

1. Small openings, widely spaced, give an effect of solidity and power.
2. Large openings, crowded, make the design appear weak.
3. Windows should be grouped vertically.
4. Windows should be placed in an odd number of rows.
5. Windows and doorways are generally made twice as high as they are wide.

117. Decoration. Ornament must be judiciously applied; unless it arises naturally out of the constructive needs of the building and forms an integral part, it should not be introduced. Ornamentation is subservient to construction; for, not only is the former dependent upon the latter for its existence, but it can be shown that all decoration is an evolution and that its origin can be traced to some practical need. Thus, the entablature is but an

elaboration of the simple overhang on a roof to keep the water away from the face of the wall, or to shelter from the glare of the sun; the widening of the capital and base of a column is dictated by practical necessities; the arch was invented to span wide openings, and to carry heavy superimposed loads. The list might be extended, but those given are sufficient to show the derivation of ornament and its complete dependence upon construction. The æsthetic element in architecture should never rival or outweigh the practical. Ornament must never be superficial. Beauty should be wrought into the very structure.

Ornament applied to one or two points of interest calls attention to the salient features of a composition. The eye is first attracted to these important points and then naturally moves along, until it takes in all the subsidiary elements of the design. Conservatism in the use of ornament leads to refinement, harmony, and unity. Lavishness, on the other hand, distracts attention, makes no differentiation between the prominent and minor features of a composition and ultimately leads to vulgarity in design.

118. Style. In classic antiquity and in fact all through the Middle Ages, the duties of an architect were comparatively few and simple. Rare, indeed, was the case where he did not combine with his profession one or more of the other arts and sciences. Michael Angelo, the sculptor, Raphael, the painter, Perrault, the physician, Wren, the

mathematician, are a few conspicuous examples. At the present time, however, building has become so wide in range, and so complex in its constructive processes and materials, that specialization is the natural consequence.

Despite its highly technical character, architecture is a subject that is susceptible of treatment appealing intensely to the interests of the student. There is no art or science more intimately connected with our everyday life. It touches the life of man at every point.

On account of this intimacy, architecture has been referred to as the index or mirror of civilization, for it reflects most accurately the character of the times, the moral tone of the people, the religious sentiments, and the intellectual and political achievements of the age in which the work has been produced. History furnishes many such illustrations. Without the architectural remains of the Egyptians, their history would have been a closed book to us. The high state of culture and civilization of the Greeks and the Romans is unerringly reflected in their superb monuments.

It is a mistake, however, to believe that all that is noble in architecture can be found only in the products of the past. Reverence has chained the mind to antiquity, but the glorious monuments of Greece, Rome, and the Renaissance, have been equalled and in a sense surpassed in modern times. All architecture is endemic. It is

peculiarly adapted to the country, the people, and the conditions that brought it into being. The beginner is apt to copy blindly from the past, deluding himself into the belief that the more fragments of some ancient masterpiece he introduces into his work the greater will be his success as a designer. Nothing can be more erroneous. A study of the classics of architecture will reveal that they were all conceived to supply a definite need. Moreover, all architecture is dynamic. It is a living art vitally and inseparably connected with contemporary life. The skyscraper was brought into being to meet a new economic condition, namely, the limited area of land available for building purposes.

Every building is born of some human need. Nothing could be more discordant, therefore, than to copy a style that is conceived for a particular purpose and that represents the ideals of a particular people at a particular time and place, and to apply that style, wholly, to another structure that is totally at variance with the conceptions of the original, "Beauty," says Millet, "is that which is in place."

We should study the past achievements of the master designers of all periods to see how their monuments can be made to serve present day needs. A survey of the conditions that lead to the creation of the epoch making styles of architecture, will reveal the very important fact

that *adaptation and not imitation* has ultimately led to the evolution of a new style.

By **style** in architecture is meant the prevailing artistic manner of treating buildings of a given period. All architectural styles have sprung from four basic structural principles of architecture; namely,—the pier, the lintel, the arch, or the truss.

A **pier** is an upright member; it is characteristic of all monuments antedating the classic era.

A **lintel** is made up of a single horizontal crosspiece or beam resting on two or more vertical supports. The Egyptians first used and the Greeks later developed this form of construction.

An **arch** consists of several blocks supported by mutual pressure and by vertical uprights called abutments. It is the distinguishing characteristic of all Roman architecture. The Roman arch is semicircular in form. Later, two arcs of intersecting circles were used so as to form a pointed apex. This style of arch forms the basis of Gothic architecture.

The **truss** is a combination and elaboration of all the structural principles thus far considered. It is an assemblage of members so arranged that each piece takes care of the strain to which it is subjected, the whole acting in unison. This form of structure admits of the bridging of very wide spans and is the basis of modern construction.

APPENDIX I

SPECIFICATIONS

119. Object. Since it is impossible to represent graphically all the information necessary to erect a building, *specifications* must be written to supplement the drawings. Plans portray the design of a structure, while specifications outline the conditions of its erection. It was stated in the early part of this work that working drawings are necessarily of a conventional character and, hence, convey only a limited amount of information. They indicate the form of an object, the dimensions, and the relations of its component parts, while specifications, on the other hand, describe the kind and finish of the materials employed, and the quality of workmanship that must be brought to bear upon its construction.

120. Scope. Specifications should cover, in a clear and explicit manner, every point not included in the plans. Nothing should be taken for granted and no loophole left for the substitution of inferior materials or for any makeshift in construction. In addition to conveying information about materials and workmanship, the specifications should clearly define the relations of the contracting parties that responsibility may not be shifted.

121. Order. The order of writing the specifications should follow closely that of the actual execution of the work. A separate set of specifications is written for each branch of the work; thus there are *mason's, carpenter's, plumber's specifications*, and so on.

Whether the contract is let in sections or awarded to one general contractor, who may or may not sub-let portions of the work, separate specifications are a great convenience.

Every set of specifications is prefaced by a paragraph setting forth the name of the owner of the proposed work, its location, the name and address of the architect, etc. This paragraph reads as follows:

Specifications of the labor and materials to be furnished in the erection of a house to be constructed for at in accordance with the accompanying drawings and these specifications and under the supervision of
Date Architect
Address

122. Index. An index precedes a complete set of specifications if they are of any great length. This index may be arranged as shown below:

| Title. | Page. |
|--------------------------|-------|
| General Conditions | |
| Masonry | |
| Plastering | |
| Steel and Iron | |
| Carpentry | |
| Hardware | |
| Painting | |

| Title. | Page. |
|------------------------------|-------|
| Glazing..... | |
| Plumbing..... | |
| Gas Fitting..... | |
| Electric Wiring..... | |
| Heating..... | |
| Roofing and Sheet Metal..... | |

123. General Conditions. A statement sufficiently comprehensive to include any kind of building operation, introduces every specification. In the event that the contract is let to one general contractor, this introduction need be given but once. Among the principal conditions set forth in this statement, the following may be cited: The duties and obligations of the contracting parties; the interpretation of plans and specifications; the course to be followed in case of conflict or omission; materials, and workmanship.

Several items included under "General Conditions" are given below:

Workmanship and Materials. All materials are to be the best of their several kinds as herein specified; all labor must be performed in the best manner by skilled workmen, and both materials and labor are to be subject to the approval of the architect.

The contractor shall furnish all materials, utensils, scaffolding, labor, transportation, etc., required for the performance of the work herein specified.

Compliance with Laws. The contractor is to comply with all laws and ordinances in force in the state, and city, and he shall be held liable for all penalties imposed on account of any violation of said laws in the construction of the building. He shall be liable for all penalties and for all damages to life or limb that may occur due to his negligence or that of his employees, his sub-contractor or people furnishing material to him for the

erection of the building, and should any such accidents occur, or damage, the contractor shall make good and pay for the same, and shall defend, at his own expense, any and all suits at law arising from such causes. He shall obtain and pay for the necessary permits for dumping, placing materials in the street, sewer and service connections, etc.

Drawings. The drawings referred to in this specification are as follows:

1. Basement plan or excavating plan.
 2. First floor plan.
 3. Second floor plan.
 4. Roof plan.
 5. Front and rear elevations.
- Etc.

Explanation of Drawings. Anything which is not shown on the drawings, but which is mentioned in the specifications, or vice versa, or anything not expressly set forth in either but which is reasonably implied, and any labor evidently necessary to the completion of the work shall be furnished and performed the same as though specifically shown and mentioned in both. Should anything be omitted from the drawings or specifications which is necessary to a clear understanding of the work, or should any error appear in the various instruments furnished or in the work done by other contractors affecting the work included in this specification, it shall be the duty of the contractor to notify the architect. In the event of the contractor failing to give such notice, he shall make good any damage or defect in his work caused thereby.

Figured dimensions shall govern scale measurements, and full size and large scale details shall be preferred to small scale drawings; but measurements are, in all cases, to be checked by the contractor from work in place at the building.

Removal of Rubbish. The contractor shall remove all débris and rubbish resulting from his work from time to time, as the

superintendent shall direct, and shall keep the premises neat and tidy.

124. Mason's Specifications. That section of the contract which is given to the mason for execution has among its principal divisions the following:

Excavation. Under this heading are included such items as excavating, blasting, backfilling, grading, shoring and underpinning.

This contract is to include all excavating for cellars, areas, foundations, footings, drains, etc., of dimensions and to depths shown on the drawings, or required by the grade. All excavations for walls to be 12" larger all around than shown on the drawings. The top soil, or all loam, to be separated and deposited where directed, so as to be used for top dressing, when the grading is done.

The mason shall do all blasting of rock that may be required to clear the site of the building; the rocks to be used in the new foundations and walls, or to be sunk where directed.

Materials. *Cement, mortar, concrete, etc.* Under each respective head is given a full description of the properties and proportions of the ingredients that compose the materials and the manner of mixing and laying them.

Cement. The cement shall be Atlas Portland, or other Portland that may be approved by the superintendent.

Lime. The lime shall be best quality hydrated lime.

Sand. The sand shall be clean, sharp building sand, free from loam or other impurities.

Broken Stone. The broken stone shall be clean and sharp, free from dust and of a size that will pass through a two-inch ring or smaller.

Mortar. The mortar shall be composed of one (1) part Portland cement, and three (3) parts sand. Add enough water to

form the proper consistency. No mortar shall be reused or re-tempered.

Concrete. All concrete shall be mixed as follows: One (1) part Portland cement (Rosendale cement may be used for cellar floors), two (2) parts sand, and five (5) parts broken stone.

The sand and cement shall be mixed into mortar as specified; the aggregate drenched and drained, mixed with the mortar until each piece is thoroughly coated, then immediately put into place in continuous layers, and tamped until free mortar appears on the surface.

Stonework, Brickwork, Terra-cotta, Etc. As an illustration of the manner in which these subjects are treated, the following clauses relating to brickwork will suffice:

Common Brickwork. Brick to be first quality common brick, hard burned, square edged, well shaped, and of a uniform size, free from swollen clinkers, or broken brick, and satisfactory to the architect or the superintendent. All brick shall be thoroughly saturated with water just previous to laying, and laid with flush joints not less than $\frac{1}{4}$ inch thick, in full beds of mortar, with all joints full and slushed up every course.

All brickwork shall be built level, plumb, square, and true, well bonded and bedded in mortar, with every sixth course a header course throughout the walls. Bats and broken bricks shall not be used in any part of the work, except where it is necessary to cut brick to make the sizes given on drawings. No brick shall be laid in freezing weather.

Face Brick. Face brick shall be pressed brick of an approved (light gray) color, harmonizing in color with that of limestone or sandstone. The facing must be well bonded to the body of the wall.

anchors, Plates, Etc. Build in all anchors, anchor plates, and bed all beams, channels, etc., in a firm, secure, and approved

manner. Beams, channels, plates, etc., to rest on a perfectly firm and solid bed.

Chimneys. Build the chimneys of hard brick in mortar made with one part cement to two parts lime, with flues (8"×8" or 8"×12") as shown on the drawings; above roof to be of selected brick laid in mortar made with equal parts of lime and cement, and the upper four courses to be laid in clear cement. The brickwork of chimneys to be kept in all cases at least one inch clear of any woodwork. All "widths" to be four inches thick, well bonded into the walls, and all flues shall be lined with terracotta flue lining and carried up separately to the top.

Turn 4-inch trimmer arches, on centers, to all fireplaces.

Plastering. The plastering shall conform to the following specifications:

Lathing. All walls, ceilings, and partitions, except the side walls of the cellar, are to be lathed with sound, dry (spruce or cypress) lath, all laid horizontally, $\frac{1}{4}$ " apart, joints broken every sixth lath, and well nailed to every bearing.

Where irregular or curved surfaces occur, metal lath (of $\frac{3}{8}$ " mesh, No. 20 wire cloth or No. 24 U. S. gauge) shall be used. All metal lathing shall be coated to prevent rust.

Plastering. All plastering shall be three-coat work, except the finish coat which may be omitted back of base and wainscoting.

Scratch and Brown Coats. The scratch coat shall be composed of $\frac{1}{2}$ bushel of goat hair and 1 barrel of lime to 3 of sand; and the brown coat of 1 barrel of lime to 6 of sand and one-quarter bushel of hair; all to be thoroughly worked and stacked at least 8 days before using.

Finish Coat. The finish coat shall be composed of white plaster-of-Paris lime putty, and fine washed sea sand.

All work shall be done in the most workmanlike manner, walls and ceilings plumb and even, angles sharp and true.

125. Steel and Iron Work. If the job warrants it, a separate specification is written for all the steel and iron work; but in a moderate-sized building it is embraced in the mason's contract.

Extent of Work. The contractor shall furnish, fabricate, paint and erect all the steel and iron work shown on plans, and as described in these specifications, and necessary to finish completely this part of the contract. The sizes of all beams, channels, angles, plates, etc., are shown on plans and no deviation of any kind will be permitted from these sizes.

Drawings. Drawings referred to in this specification are the general scale drawings and also the special steel framing plans. The contractor shall submit to the architect for approval all shop drawings and details. The approval of these will be only as to strength, and does not relieve the contractor from responsibility for his dimensions. Approved shop drawings shall be used in setting all work.

Quality of Material. The material used in this structure shall conform to "Manufacturers' Standard Specifications" as published in the Carnegie Steel Company's handbook.

Rivetting and Bolting. Rivets and bolts for structural steel shall be $\frac{3}{4}$ " in diameter. Rivets shall be used for all such connections of beams and girders as may be indicated on drawings. All rivets shall, when driven, be tight, fill the holes completely, and have full heads concentric with the hole.

Inspection and workmanship are then taken up in detail.

Painting. All scale, dirt and foreign substances to be removed before painting. All surfaces to receive one coat of Graphite Paint No. 35 after the pieces are punched and before they are assembled. All surfaces accessible after the material is erected shall have a second coat of Graphite Paint No. 30.

All painting shall be done on dry surfaces.

126. Carpenter's Specifications. All the items of wood-work in connection with the construction of a building are collected and systematically itemized in the carpenter's specifications.

Framing. All framing timbers to be carefully selected, of the dimensions given and to be put up straight and true.

The sills are to be halved at the corners and bedded in mortar. The corner posts shall be tenoned into the sill and well braced. The girts shall be mortised and tenoned into the posts and secured with oak pins.

Double the floor beams under all partitions running the same way. Beams built into a masonry wall shall have a 3" firecut.

Frame around all chimneys, wells, and other openings, placing no timber within 2" of brickwork of chimneys. Headers and trimmers to be doubled and spiked. Headers that carry more than three tail beams to be hung in W.I. stirrups.

Bridging. All floor beams to have one row of (1¼"×3") cross bridging to each span of 8 feet or over, properly cut and secured at each end with two 8d nails.

Sheathing. Cover the entire frame (except on such roofs as are to be shingled) with (1"×9") rebated hemlock sheathing, surfaced on one side to an even thickness, put on diagonally, all driven up close and securely nailed to every bearing with two 8d nails. Cover over the sheathing with approved building felt, laid with not less than 3" lap. Line with the same felt under all corner boards, casings, etc.

If the sizes of the timbers are not specified on the drawings they should be given here in addition to a description of the kind and quality of the material used; thus:

Timber. All timber, unless otherwise specified, is to be of good sound spruce free from shakes, clefts, waness, and any other defects which may impair its strength and durability.

Sizes of Timbers. (Dimensions in inches.)

Sills 4×6 to 4×10.

Girders 6×8 to 8×10, yellow pine.

Floor joists 2×8 to 3×10, 16" on centers.

Ceiling beams 2×6.

Collar beams 1×10, placed on every second pair of rafters.

Headers and trimmers 4" by the depth of the beam, or joists doubled.

Posts under girders 8" square; 6" or 8" round.

Posts at corners and angles, 2×4 spiked to 4×6 or 4×8.

Braces 2×4 and 4×4.

Girts 4×6 and 4×8.

Ribbon 1×6.

Plates 4×4 and 4×6.

Studs,—walls and partitions—2×4 hemlock, spaced 16" on centers throughout.

Studs,—bearing partitions and around openings—3×4 or two 2×4.

Rafters, common, 2×6 to 2×8; hip 2×9; valley 3×9.

Sheathing ¾×6 and ¾×8.

Finished flooring ¾×4.

Exterior Finish. Material. All exterior finished wood, except where otherwise specified, to be (pine or cypress) free from all sap, shakes, knots or other defects of any kind.

Walls. Exterior walls to be covered with the best clear white pine clapboards, (6") wide, laid with 1¼" lap, well nailed to every bearing with 6d nails set in for puttying.

Roofs. Shingles. Cover the roof, where marked "shingles," with xxx sawed pine shingles 18" long, laid 5½" to the weather and secured with at least two 4d nails to each shingle. All roof shingles are to be laid on 1×2 spruce lath placed the proper distance apart for nailing.

Unless cornices, water table, belt courses, etc., are drawn to an enlarged scale, they should here be described in detail, thus:

Water Table. The water table shall be $1\frac{1}{4}'' \times 8''$ and shall have a $1\frac{1}{4}'' \times 2\frac{1}{2}''$ cap with tongue on its upper end and finished with a $1'' \times 1\frac{1}{2}''$ ogee molding under cap.

Stock. All stock for interior finish to be the best quality of the kind specified, thoroughly seasoned, and kiln dried, free from all knots and sap wood, well hand smoothed, and sandpapered before putting up.

Interior Finish. Trim and Base. All windows and doors and finished rooms throughout the building are to be provided with trim and base, to be thoroughly seasoned and dried and in accordance with detailed drawings.

The woodwork for all trim and finish in respective rooms and all halls shall be of the following description, unless specified to the contrary:

White Pine. Use clear white pine for sash in frame and exterior walls.

Birch. Use first quality birch in the following rooms: (specify rooms).

Oak. Use first quality quartered white oak in the dining room (mention other rooms).

Flooring. Rough flooring to be $1'' \times 6''$ N. C. pine, tongued and grooved, laid diagonally on the joists and blind nailed at every bearing with two 8d nails. Flooring to extend close to outside sheathing and to be well fitted around all studs.

Finished floor for (kitchen) to be $2\frac{1}{4}''$ face maple; (dining room, living room, and hall) to be $2\frac{1}{4}''$ face red oak; all other floors to be yellow pine dressed and matched, blind nailed to every bearing and to be scraped and smoothed at all joints.

Window Frames. All window frames unless otherwise shown, to be made for double hanging sashes, using best quality sash cord and $1\frac{3}{4}''$ steel axle pulleys with lacquered iron faces and with

iron weights to balance the sashes. All jambs and heads are to be $1\frac{1}{4}''$ thick of N. C. pine, to have 2'' sills and $\frac{7}{8}''$ sub-sills. Cellar sashes are to be arranged to swing in and are to be hung with two brass butts; two small hooks and one button to be placed on each sash.

Door Frames. All door frames are to be blocked solid for hinges and locks; jambs are to be of cypress $\frac{7}{8}''$ thick, and are to have $\frac{1}{2}'' \times 2''$ stops of cypress. All outside frames to have 2'' oak sills and $1\frac{1}{4}''$ jambs and casings.

Doors. All doors are to be paneled and molded in accordance with the scale and detailed drawings furnished for the same. All wood in the door to be well kiln dried. All doors to be blind tenoned.

All veneered doors shall have white pine built-up cores and ($1\frac{1}{4}''$) veneering well glued on both sides.

All doors shall be constructed of wood corresponding with the finish of the room in which they occur.

Hardware. All rough hardware required to complete the carpenter's contract must be furnished by this contractor. The contractor to allow (\$200) for all finished hardware, which is to be selected by the architect and purchased by the contractor. Should the amount exceed this sum the owner will pay the additional cost; if less, the amount will be deducted from the total amount due to the contractor.

127. Painting. The painting and glazing specifications should be as follows:

Painting. Workmanship and Materials. All materials to be of the very best of their several kinds in quality as herein specified, to be delivered at the building in the original packages with seals unbroken and labels attached, and must not be opened until inspected by the architect.

Shellac all defective surfaces before priming. Putty up all nail holes, cracks, etc., after priming.

Exterior. Paint all sash, frame, and all exterior woodwork, all iron railings, grills, and all other exterior iron work with three (3) coats of pure lead and oil, tinted as directed by the architect.

All shingles to be dipped, while perfectly dry, in good creosote oil stain, the color to be selected by the owner and to be given one brush coat after laying.

Interior. All the trim of principal rooms and halls to receive one coat of stain filler and three coats of approved hard oil finish rubbed down between coats and left with a dull finish.

Floors. Oak floors after being dressed, planed and scraped by the carpenter shall be finished as follows:

First, fill with one coat of paste filler carefully rubbed off after being set. Then apply one coat of shellac and, over this, two coats of an approved wax rubbed down with a weighted brush after each coat.

Graining, staining, and kalsomining are treated in a similar manner as above, detailed specifications for which may be obtained from any paint manufacturer.

Glazing. Glass for cellar sash shall be first quality double thick American glass, free from flaws, stops, or any other imperfections; glass to be securely fastened in place and be well bedded in putty, tacked, and neatly traced. Glass for all other sash shall be (best clear French plate), well bedded, tacked, and puttied. Art glass, where shown, to be provided by the owner and set by the contractor.

128. Plumbing Specifications. This work consists chiefly of sanitary fixtures and gas fitting to be furnished, set and connected and the extending and connecting of drains, water and gas supply lines.

All work of the plumbing contractor shall be done in accordance with local ordinances, anything shown on the drawings or this specification to the contrary notwithstanding.

When the entire plumbing system is completed, the plumber shall turn on the water supply and leave the entire system in perfect working order. He is to guarantee his work for one year from the date of completion, and repair all damages caused by defects in his workmanship or materials during that period.

The arrangement of all pipes must be as straight and direct as possible. Offsets will be permitted only when unavoidable and must not be made at an angle of less than 45°.

Materials and Workmanship. All materials shall be of the best quality, free from all defects, and all work must be done in a workmanlike manner.

Cast iron pipe and fittings shall be sound, cylindrical, and smooth inside, free from all defects, of a uniform thickness and of a grade known in commerce as "extra heavy."

All wrought pipe shall be lap-welded and of the grade known in commerce as "standard" with the maker's name stamped thereon. Wrought iron pipe shall be evenly cut, well reamed, and all burrs completely removed.

Lead pipe shall be drawn pipe of the best quality and of the grade known in commerce as "AA."

Brass ferrules must be best quality, bell shaped, extra-heavy cast brass, not less than 4" long.

The brass pipe used in connection with this work must be of the best quality, annealed, seamless, drawn tubing, of standard iron-pipe gauge, plain, polished, nickel-plated, or tinned as required.

House Sewer. All sewer pipes to be first quality vitrified clay pipe with socket joints laid upon a solid bed with uniform fall to the outlet. All joints to be bedded in fresh Portland cement, wiped smooth on the inside. Changes in direction to be made with long bends.

House Drain. The house drain shall be the required lengths and sizes of extra heavy cast iron pipe when under ground, and of galvanized wrought iron when above ground.

The house drain and sewer shall be at least (4") in diameter and greater if they discharge rain-water.

The house sewer shall be connected with the house drain at a point two feet outside of the front wall of the building.

Trap the house-drain with a (4") extra-heavy cast iron running trap placed just inside the front cellar wall. This trap must have two cleanouts, with brass screw cap ferrules calked in.

Fresh Air Inlet. A fresh air inlet shall be connected with the house drain just inside the house trap and shall be of the same size as the drain pipe up to 4 inches.

Standing Soil, Waste, and Vent Pipes. Connect one 4" cast iron soil line with the house drain. The soil line shall have 4" TY branches for water-closets and 2" Y branches for other fixtures.

Connect one 3" main waste line as shown on the plans; branch waste pipes shall be 2", all of extra heavy cast iron.

Connect each line of soil and waste at the foot of the house drain and run independently in full caliber above the roof.

Fit up 2" galvanized wrought iron vent lines, as indicated on the drawings. Provide 2" branches for water-closets, and 1½" branches for other fixtures.

Where soil, waste, or vent pipes extend above the roof, they shall be at least 4" in diameter, the increase, if any, being made below the roof surface. At no part of the roof is the pipe to be less than 3 feet above it.

All soil, waste, and vent pipes passing through the roof shall be so arranged as to prevent leakage. For this purpose the contractor shall use a flashing of 20-ounce sheet copper, 20" square and a copper tube of like weight 15" long soldered to the same. This is to be slipped over the pipe and a recessed coupling screwed down over the copper tube. The flashing must be neatly and perfectly secured to the roof, and the soil, waste, or vent pipe continued up from coupling the required height.

Leaders. Inside leaders shall be of cast or wrought iron and

trapped with cast iron running traps so placed as to prevent freezing.

Outside leaders shall be of galvanized iron (copper), and, if connected with the house drain, shall be of cast iron pipe, trapped on the inside.

Leaders shall not be used as soil, waste, or vent pipes, nor shall any such pipe be used as a leader.

Traps. Traps shall be of the same weight and thickness as their corresponding branches, well supported and set true with respect to their water seals.

Traps shall be placed as near the fixtures as practicable and so arranged that in no instance will the waste from a fixture pass through more than one trap before entering the house drain.

All traps shall be placed in such locations or be so arranged as to be readily accessible and shall be fitted with approved heavy cast brass screw plugs.

Every fixture must be separately trapped and no trap shall be more than 2 feet from any fixture.

Connections. All joints in cast iron pipe shall be made with picked oakum and molten lead, made impermeable to gases by imbedding the lead with hammer and calking iron.

Where lead connections are made to wrought iron pipe, brass pipe soldering nipples, the same size as the branch of wrought iron pipe, shall be used and the joints shall be wiped.

Threaded connections on brass pipe must be of same size as iron pipe thread for the same size of pipe and must be tapered.

All connections between lead pipe and between lead and brass or copper pipes shall be made by means of wiped solder joints.

Supports. The entire vertical drainage system, comprising the leader, soil, waste, and vent lines, shall be supported on the floor beams by means of wrought iron clamp hangers of approved pattern. All horizontal parts of the system shall be supported at intervals of not over 5 feet by being hung from the floor beams on heavy adjustable wrought iron hangers.

Water Supply. Tap the water main in street; connect and run to the building a line of "AA" lead supply pipe. Place one stop cock or valve under the sidewalk at the curb and another upon the service pipe just inside the front wall; continue in the building with a 1" line of galvanized wrought iron house main, with $\frac{3}{4}$ " branch to fixtures.

Arrange all lines so that the hot and cold supply can be shut off from each group of fixtures independently.

All rising lines shall have a stop cock at the foot of each line.

Diameters of branches to any fixtures shall not be less than $\frac{1}{2}$ " except water-closet branches which shall not be less than $\frac{3}{4}$ " in diameter.

The distance between hot and cold risers shall in no case be less than 6".

Fixtures. The following fixtures are to be furnished, set and connected ready for use.

Kitchen. 1-24"×18" porcelain enameled roll rim sink and back, *all in one piece*, with iron brackets, with N. P. compression faucets, with N. P. trap, with N. P. open strainer, with galvanized concealed air chambers.

1-18"×6" galvanized hot water tank to hold not less than 60 gallons and tested to 250 pounds of pressure, mounted on an iron pedestal, etc. (Specify in detail all other fixtures, giving name of manufacturer, catalogue number, etc.)

All fixtures are to be connected and the entire plumbing system is to be made complete and ready for use.

The general contractor will do all the cutting and digging required for the plumber. The plumbing contractor is to run the house drain two feet outside of the building and to make proper connection with the drain to the sewer.

Tests. When each house drain and all the soil, waste and vent branches connected thereto are entirely roughed in, all openings are to be plugged and each system filled with water to the height of the building. Any defects in material or work-

manship which may appear shall be permanently repaired and the tests repeated until the work is entirely satisfactory.

A smoke test shall be applied and a written notice shall be given to the architect when all fixtures, drain, soil, waste and vent pipes are connected and in complete working order as required by the plans and specifications, whereupon an approved smoke testing machine, together with the materials shall be furnished by this contractor at such time as the owner shall designate and a smoke test of the entire system shall be made in the presence of the owner or such person as he in writing may designate. The final certificate shall not be signed until this test has been made and the work proved tight to the satisfaction of the owner.

Gas Fitting. All necessary gas pipe and fittings of proper sizes shall be furnished and run to outlets as designated on the plans.

The sizes of pipe shall measure internal diameter. The pipe used shall be of the best quality, plain, black, genuine wrought iron, welded gas pipe. All pipes shall be free from splits, flaws or other defects and of a true and uniform section. All fittings shall be heavy malleable iron, beaded, galvanized fittings. Where pipes of different sizes come together, proper reducing fittings shall be used; no bushings will be permitted.

All outlets shall be $\frac{3}{8}$ " in diameter, except for the gas range which shall be larger, and secured, plumb, in place and all outlets shall be capped until covered by fixtures.

No pipe shall be less than $\frac{1}{2}$ "; all short branches of $\frac{1}{2}$ " and $\frac{3}{8}$ " gas pipe; also, all outlets shall be of the grade known as extra heavy.

After the several lines are completed, they shall be proved gas tight by the contractor for gas fitting by ether test and mercury gauge, in the presence of the owner or other person authorized by him in writing and to the entire satisfaction of the architect and the approval of the gas company. At the completion

of the work the contractor shall furnish a certificate from the gas company.

Gas outlets of one light each are to be provided as follows and as indicated on the plans:

- Cellar, 2 outlets,
- First floor, 5 outlets, including range,
- Second floor, 1 outlet,
- Third floor, 1 outlet, etc.

All nipples are to be of the exact length required for putting on fixtures without alteration, and all are to be square with the wall or ceiling from which they project.

All bracket outlets are to be exactly 5' 6" above the finished floor.

Service pipe is to be extended through partition wall where shown on the plans and is to be capped.

129. Electrical Specifications. These specifications are intended to embrace all the labor and material, except as noted below,* necessary for the installation of wires and fixtures in the residence.

All the work herein included shall be done according to the rules and regulations of the National Board of Fire Underwriters and subject to the inspection and approval of the local Board of Fire Underwriters. The contractor shall pay all charges for this inspection, secure satisfactory certificates and deliver the same to the architect.

System. The system for lighting is (three wire, 60 cycle, alternating current, 104 volts).

Wire. The wire used in this connection shall be of the very best quality (98 per cent) conductivity, and shall be the best grade of approved standard "rubber covered."

* The general contractor will do all the necessary cutting in the concrete and mason work and will repair and make good after all cutting for the installation of the electrical work.

All wires must be of such size that the drop in potential at the farthest outlet shall not exceed 2% under maximum load. No wire shall be less than No. 14 B. & S. gauge.

Conduit. All wires, except in the basement, shall be run in approved metal conduits to all outlets marked on the plans or specified. No wires shall be drawn in until all mechanical work on the building is done and until after the plastering is dry.

Wires of different circuits must not be drawn in the same conduit, but the two or more wires of the same circuit should be drawn in the same conduit.

No smaller conduit than $\frac{1}{2}$ " inside diameter shall be used; all conduits shall be securely fastened by approved clamps or metal straps; conduits shall be run under the plaster of side walls and under the flooring.

All conduits shall be permanently and effectually grounded. No connection for ground with any gas or water piping within the building will be allowed.

After the wiring is completed it shall be tested, and all defects shall be made good.

Switches and Fuses. The main switch and cut-out, meter board and other cut-outs as required, are to be furnished and installed by this contractor. The main switch is to be of an approved knife type of ample capacity and mounted on a slate base, properly inclosed, and located as directed. The switch is to be connected and wired complete to receiving meter; all fuse posts shall be furnished with Noark, D. W. or other approved, screw clamp, contact pattern, inclosed fuses, with blowout indicators on the front of the fuses.

Fixtures. All fixtures shall be cemented and properly set. The electric and combination fixtures shall be put up complete, including all wire attachments of sockets, etc., with wiring and insulating joints. •

All joints in the gas piping shall be made tight with red lead so as to be entirely free from leakage under the full pressure of

the gas mains. After the fixtures are in place they shall be proved by air test with mercury gauge. The air pressure shall raise a column of mercury six inches in height and maintain the same for thirty minutes. The test shall be made in the presence of the owner or of a person designated by him.

Schedule of Lights.

Basement:

- 5 drop lights, 16 c.p. each.
- 1 bracket light, one 16 c.p. combination.
- 1 ceiling light, one 16 c.p. (on stairs) controlled by a switch at the head of the stairs.

First Floor:

- Porch:—1 ceiling light, one 16 c.p., controlled by a switch in the front hall.
- Front hall:—1 ceiling light, one 16 c.p., controlled by switch. Etc.

All side outlets are to be exactly 5' 6" above the finished floor.

The owner will furnish all fixtures and switches required in the above schedule, except drop lights and the main switch; and the contractor is to install properly and connect the same. All other materials are to be furnished by the contractor.

All the work under this contract is to be complete and ready for use, thoroughly tested, and warranted for one year after acceptance.

Bells. Install electric bells as follows:

- A bell from the front door to ring in the rear hall.
- A bell from the north, side door to ring in the rear hall.
- A bell from the rear outside door of the refrigerator room to ring in the rear hall.
- A foot-bell from the dining room to ring in the kitchen.

Bells from the sitting room and the second story hall, to ring in the kitchen and attic hall.

All bell wires are to be run behind the plastering in tubing of suitable material and dimensions; said tubing to be imbedded where necessary in the concrete or plaster. The owner will furnish all push-buttons, bells and batteries. The contractor will furnish the wire and all other materials necessary and properly install the buttons, bells and batteries as directed, leaving everything complete ready for use.

130. Heating Specifications.—Hot Water.—This specification contemplates a complete two-pipe circulating system, guaranteed perfect in every respect.

Quality of Materials. All materials used in the construction of this apparatus are to be the best of their respective kinds, all fittings to be heavily beaded and made of the best gray iron with clean-cut threads, and, when practicable, Y's and 45° L's are to be used.

Heater. Furnish and set up in the cellar, where shown on the plan, one (specify name of manufacturer and number of apparatus) water-boiler guaranteed free from all flaws and defects.

The heater to be set on a substantial foundation of concrete put in by the general contractor.

Furnish and deliver one complete set of fire tools.

Smoke-pipe. Connect the boiler to the chimney by means of smoke-pipe made of (No. 20) galvanized iron, the diameter of the pipe to be equal to the outlet on the heater.

Trimnings. The boiler to be provided with one expansion thermometer registering from (80° F. to 250° F.). Attach to the main flow pipe, near the boiler, one Standard altitude gauge.

Water Connections and Blow-off. Feed-water with its supply pipe will be brought within (6 ft.) of the boiler by the plumber

and left with one ($\frac{3}{4}$ -inch) cast-iron fitting for boiler connection, which is to be made by this contractor, connection to be provided with a suitable cock.

A draw-off cock is to be placed on the lowest point of the system and to be fitted for hose-nipple attachment.

Pipes. Furnish and run all necessary flow and return pipes of ample size, connecting them to radiators with pipes of ample size to insure the free and rapid flow of hot water to the radiators and the easy flow of the cooler water back to the heater.

All connections from the risers to the radiators are to be made below floors.

All flow and return pipes in the basement are to be supported by neat, strong, adjustable hangers, arranged to allow suitable expansion and contraction, and properly secured to timbers overhead.

At all points where pipes pass through ceilings, floors, or partitions, the pipes shall be encased in iron or tin tubes and the holes protected with floor or ceiling plates.

All ells, tees and crosses used shall be long radius.

The proper pitch upward for all horizontal pipes carrying hot water and the downward pitch of all pipes carrying the cooled water are to be observed.

Reaming. The ends of all pipes used in the construction of this apparatus are to be reamed out and all obstructions removed before the pipes are placed in position.

Expansion Tank. The expansion tank is to be made of (No. 22) galvanized iron, (30 inches) high and (16 inches) in diameter, and is to be furnished with a proper gauge-glass with brass mountings complete. It is to be placed above all the radiators, in some suitable place, and supported on a proper shelf. From this tank an overflow pipe shall be run to the basement or other suitable place with a vent pipe through the roof.

Radiators. Furnish and set up the following radiators, viz:

| Room. | Size. | Sections. | Sq. Ft. |
|----------------------------|---------|-----------|----------|
| Parlor..... | 18×55 | 22 | 49.5 |
| Sitting Room..... | 26×25 | 10 | 37.5 |
| Dining Room..... | 26×17.5 | 7 | 26.25 |
| Hall..... | 26×5 | 2 | 7.5 |
| Etc. | | | |
| Total, (12) Radiators..... | | | (374.25) |

In all (462 sq. ft.) of direct, (162 sq. ft.) of indirect, plus (200) for piping loss; total surface (824 sq. ft.).

The direct radiators to be (specify the manufacturer's name) hot-water pattern, plain.

Air-valves. Each radiator shall have properly connected to it a nickel-plated air-valve to be opened and closed with a key.

Radiator Valves. All direct radiators shall be properly connected to the system of piping with an approved quick-opening, nickel-plated radiator valve and union elbow.

Radiators are to be connected at the top and bottom.

Indirect Radiation. The indirect radiators shall consist of (seven) sections of (specify manufacturer's name) hot-water radiator, connected together with tight joints and firmly suspended from the basement ceiling by suitable wrought-iron hangers.

The stack shall be so piped and hung as to permit a quick, noiseless, and constant flow of the heated water throughout.

The stack is to be enclosed in a galvanized iron chamber with proper inlet for fresh air and a corresponding outlet for warm air, and connected by a galvanized pipe to the registers in the rooms which the stack is intended to heat.

The registers are to be of approved pattern, electro bronze plated, and of the following sizes: hall, (10×14); sitting room, (10×14); dining room, (10×14).

Covering of Pipe. All flow and return pipe and fittings in the cellar above the floor to be properly covered with asbestos or magnesia sectional covering with canvas cover and secured by brass lacquered bands.

Boiler Covering. Cover all exposed parts of the boiler, except the front, with plastic asbestos $1\frac{1}{2}$ inches thick, neatly applied and trowelled smooth.

Regulator. Furnish and install, where directed, an approved regulator (No. 2) complete, properly connected with check damper in the smoke pipe, and left complete.

Workmanship. All work is to be done in a neat, substantial,

and workmanlike manner, and the apparatus, when completed, is to be thoroughly tested and left in good working order.

Testing. Upon completion of the work herein specified, the apparatus shall be tested in the presence of the architect. The owner shall supply all necessary fuel for testing said apparatus.

Guarantee. The contractor is to guarantee that the apparatus, when completed in accordance with this specification, will be of ample capacity to evenly maintain a temperature of 70° F. in the rooms in which radiators are located, when the outside temperature is at zero, and that the apparatus throughout will have a free and rapid circulation when in operation.

APPENDIX II

ESTIMATING

THE highly technical character of estimating precludes the possibility of discussing this subject exhaustively. An attempt will be made in these pages to make a few statements concerning the conditions that affect all estimating and the various methods employed in arriving at the cost of a projected building.

131. Cost. The most difficult problem attached to estimating is the cost of labor and material because wages and prices vary. In no two localities are prices exactly alike, and in the same locality they are constantly fluctuating. One must, therefore, study local market conditions and be fully conversant with current prices of labor and materials before he can submit a fair and reasonable estimate. If the estimate is too high, the contract will be awarded to a competitor, and if too low, the contract will have to be carried out at a loss. To guard against the latter contingency, the following matters are usually attended to before commencing the actual calculations of cost: The contractor should visit the site of the building with a view to ascertaining exact conditions. He should make inquiries regarding the nature of the soil, the facilities for transportation, and labor conditions. All these are items that have a direct bearing upon the cost of the building. If the ground is marshy or if spring or rock is encountered, the piles, draining, refilling, and blasting that are necessary to obviate these difficulties

add materially to the cost of the proposed structure. The distance of the base of operations from railroads or wharfs, the ease with which labor may be obtained, and the season of the year also affect the cost.

Catalogues and price lists are indispensable to the successful contractor. These must be constantly revised to be kept up to date. They should be carefully arranged and indexed for easy reference.

132. Estimates. Broadly speaking, there are two kinds of estimates: approximate and detailed. *Approximate estimates* are made only in cases where plans and specifications have not been fully completed or before the plans are drawn. An owner wishes to have a fairly accurate idea of the cost of the designs which have been submitted to him by the architect as studies of a projected dwelling. The efficient architect can very readily accommodate his client. Conversely, the owner wishes to spend a limited amount of money, say \$10,000, for a residence; the architect accordingly designs a house not to exceed that limit of cost.

133. Basis of an Approximate Estimate. The approximate method of estimating is based upon the following proposition: Buildings similar in style, function and material will, if built under the same conditions, cost the same. If, therefore, we know the cost of different types of structures already built, we can easily obtain

the approximate cost of a proposed structure of a similar type by comparison, ascertaining how many units of cost of the building already erected are contained in the building to be erected.

134. Methods. Several methods are used in obtaining approximate estimates, with a greater or less degree of accuracy. One method in common practice is to estimate by the cost per *square foot of floor area*. This method is convenient in obtaining approximate costs of office buildings, loft buildings, and other buildings where the plan of one floor is typical of the arrangement of all floors. Another method is by the cost per *unit of accommodation*. This method is of particular advantage in calculating the costs of such structures as schools, churches, hospitals, theaters, prisons, etc. The system of estimating, however, that is attended with greatest success and accuracy, is that of *cubing*. This method consists of finding the cubic contents of a proposed structure and multiplying that by the average known cost per cubic foot of structures already built, and as nearly alike as possible in every respect to the building upon which the estimate is being made. In finding the approximate cost of a building by this method, great care must be taken to compute its cubical contents in the same manner that was used in computing the contents of the one already erected. The plan most commonly followed is to multiply the square feet in the plan (the measurements to be taken from the outside face of the walls) by the height from the level of the cellar or basement floor to the average height of the roof. Porches, verandas, and other additions are usually figured at one-half their total cubage.

135. Detailed Method. At best all of the above methods are an approximation and are, therefore, inexact. To obtain a more accurate estimate *the detailed method*

must be followed. By this method, the actual quantities of the materials are taken off, categorically arranged and calculated, the cost of labor is figured, contingencies are provided for, a percentage of profit is added and a total is obtained that is as close to the actual cost as human ingenuity can accomplish.

The principal divisions of an estimate are given below, arranged in a form that will be found convenient in summarizing for the grand total.

Excavation,
Stonework,
Brickwork,
Carpentry,
Roof and Sheet Metal Work,
Plastering,
Heating,
Plumbing and Gas Fitting,
Electric Wiring,
Painting and Glazing,
Hardware,
Etc., etc.

Owing to the variable character of the prices for materials and of wages, the authors, instead of arbitrarily quoting prices have analyzed the subject in such a way that the student can tell at a glance the different items that enter into a particular estimate. Thus, instead of giving the price of 1000 bricks laid complete in a wall, the amount of mortar required to lay 1000 bricks and the time it would take to lay them are given, and the student, by obtaining local prices for these items, can ascertain accurately the total cost.

In estimating, follow the actual construction of the building as closely as possible. First, figure the cost of surveying, clearing the site and laying out the ground. Then measure up the amount of excavating required for the cellar walls, piers, etc. Follow this with the masonry work, concrete footings and cellar floor, stone foundation walls, and brick exterior and interior walls. Carpentry work comes next in order. Plastering, painting, glazing, plumbing, electric lighting, etc., follow in the order given. At least 5% of the total cost of the building must be added for incidentals; that is, for the use of equipment, loss, liability, expenses, etc; and 10% for profit.

Every item in the estimate should contain the following information: (1) quantity; (2) description of the work; (3) price; and (4) extension. Thus,

65 cubic yards concrete footing 1 : 3 : 5 @ \$6.50,
 \$422.50.
 1500 square feet terra-cotta block partitions, @ \$0.15,
 \$225.00.

As each item is taken off the drawings, the specifications relating to that item should be read carefully and such information jotted down as is not included on the plans.

The student is urged to follow rigidly the system herein outlined in taking off and in recording quantities. The main headings should be written in a clear, bold hand, should be numbered consecutively and underscored with a double line. All sub-headings should be underscored with a single line. Descriptive matter, dimensions, prices, and extensions of the different estimates should be placed under one another. Never use ditto marks to repeat figures.

136. Heading. Commence the estimate by giving the following information, arranged as shown below:

| | |
|------------------|---------------------|
| Location..... | Date received..... |
| Owner..... | Date submitted..... |
| Address..... | Estimator..... |
| Architect..... | Checked by..... |
| Address..... | Amount \$..... |
| Description..... | |

(A) EXCAVATION

The unit of measurement for excavation is the cubic yard. Determine the actual amount of material that has to be displaced to receive footings, foundation walls, piers, chimneys, areas, porches, etc., and multiply the total obtained by the cost of excavating per cubic yard. This rate is variable and depends upon, (1) the character of the soil; whether wet or dry, clay or rock, etc.; (2) the manner of handling the material; whether with wheelbarrow, or horse and cart; and (3) the use to which the material excavated is put; whether it is to be taken away from the premises or left there to be used later for filling in and grading. When piling or blasting has to be resorted to, the cost is greatly increased.

137. Estimating Data. Among the important items to be considered under excavating, are the following:

| | | |
|----------|---------------|---------|
| Cellar | Catch basins | Pumping |
| Footings | Pipe trenches | Piling |
| Piers | Elevator pits | Filling |
| Areas | Shoring | Grading |

Earth and clay will increase by about 30% of its original volume when excavated; sand and gravel by 16½%; loam by 20%; and rock by 50%.

When an excavation is of greater depth than 6 feet (the height which one man can throw), stages must be built, thus increasing the cost per cubic foot of material excavated. Therefore, in taking off measurements, divide as follows: "not exceeding 6 ft."; "exceeding 6 ft. but not exceeding 12 ft." etc.

Excavation for trenches for walls, piers, etc., should be kept separate from cellar excavation.

Always excavate one foot outside of the foundation walls to allow ample room for the workmen to point, etc.

In one working day two men should excavate, that is, dig and load into carts or wheelbarrows, 10 cubic yards of sand, gravel or soft clay, or about 6 yards of stiff gravel or clay.

Refilling and grading amounts to about one-third the cost of earth excavation.

138. Arrangement of Estimating Sheet. The estimating sheet should be arranged as follows:

1. Excavation.

| | | | |
|---------------------------------|-----------------------------|---------------|---------|
| <i>Cellar:</i> | | | |
| 29' 0" × 30' 0" × 4' 10" | = 4205 cu.ft. = 156 cu.yds. | @ \$1.25 = \$ | |
| <i>Trenches:</i> | | | |
| Wall, 110' 0" × 3' 0" × 1' 0" | = 330 " = 12 " | @ 1.50 = \$ | |
| Pier, 2' 6" × 2' 6" × 1' 0" × 3 | = 19 " = 1 " | @ 1.60 = \$ | |
| Total excavation..... | | | \$..... |

2. Masonry.

(See page 93.)

Note. Fractions of $\frac{1}{2}$ or more are counted 1.

(The prices given above are used only for purposes of illustration. Under no condition should they be taken as standard. Having calculated the amount of material to be excavated the student should apply to some local contractor for prices and figure out his cost accordingly.)

(B) MASONRY

139. Stonework. The unit of measure in stonework is the cubic foot, although the perch is sometimes used. A *perch* is a mass of stone $16\frac{1}{2}'$ long, $1\frac{1}{2}'$ wide, and 1' high and containing $24\frac{1}{2}$ cubic feet. To calculate by the perch, however, is unreliable because in some localities a perch is figured at 22 cubic feet, while in still others $16\frac{1}{2}$ cubic feet constitute a perch.

In estimating the quantity of stonework required the operation is as follows: The length of the wall (which is measured around the outside, thus counting the corners twice), is first multiplied by the height of the wall, and then by its thickness.

In measuring rubble masonry, no deductions are made for openings unless they exceed 15 square feet, in which case an allowance of one-half their area is made. In stone walls, openings less than 3 feet in width are disregarded; if over 3 feet, they are deducted. The practice of disregarding openings and of reckoning corners twice is accounted for by the increased cost of labor and additional material necessary in the construction of these parts.

Steps, sills, lintels, belt-courses, coping, and all other trimmings or ornamental members are measured by the lineal foot and the local prices for these items should be obtained by the student.

Estimating Data. A mason and helper will lay about 60 cubic feet of rubble in a day or about 40 cubic feet of ashlar.

It requires $\frac{1}{4}$ cubic yard of sand and $\frac{1}{2}$ barrel of cement (or if lime is used, $\frac{1}{3}$ of a barrel), to lay one cubic yard of rubble wall.

One barrel of Portland cement, 2 barrels of sand, and 5 barrels of broken stone will yield about 20 cubic feet of concrete.

140. Brickwork. A common method of calculating the quantity of brickwork, i.e., brick plus mortar required, is to figure the entire superficial area of the wall in square feet and to allow:

| | |
|--------------------------------------|-------------------------|
| 7½ bricks per square foot for a wall | 4 in. or ½ brick thick. |
| 15 " " " " | 9 " 1 " " |
| 22½ " " " " | 13 " 1½ " " |

and so on, adding 7½ bricks per square foot for every increase of 4½" in the thickness of the wall.

Outside measurements (girt) of brick walls should be taken to compensate for the time lost and the labor spent in bonding angles. No deductions are made for openings in walls built of common brick, unless the openings are large and numerous; nor is any allowance made for stone or terra-cotta trimmings. In computing for pressed brick, deduct all openings. Hollow walls are reckoned as if solid

Estimating Data. A mason and helper should lay about 1000 common bricks in 6 hours or from 450 to 550 face brick in one 8-hour day. The thicker the wall the greater will be the number of bricks that can be laid. Thus a man can lay about one and one-half times as many bricks in an 18-inch wall as he can lay, in the same length of time, in a 9-inch wall. Of course the complexity of the design, the height of the building and the season must always be taken into consideration in determining the amount of brick that can be laid in a given period.

It takes 1½ barrels of lime and ⅘ cubic yard of sand to lay 1000 bricks; if cement is used in the proportion of 1 to 3, it takes 1½ barrels of cement, ⅘ cubic yard of sand, and 10% of the mixture of lime, to lay 1000 bricks.

The following table shows the quantity of mortar required to lay 1000 brick with varying sizes of joints:

| | |
|----------------------|------------------|
| Joints ⅜-inch thick, | 8 cu.ft. mortar. |
| " ¼ " | 12 " |
| " ⅓ " | 12 " |
| " ⅔ " | 15 " |
| " ½ " | 18 " |

More generally speaking, allow ⅓ cubic yard of mortar per cubic yard of brick masonry. One thousand brick when laid up in the wall occupy approximately 2 cubic yards.

Chimneys are figured by counting the number of brick required for one course and allowing 5 courses to the foot of height.

141. Table of Quantities. The following equivalents will often be found useful:

4 bags make 1 barrel of cement.

2½ bushels of lime or cement make one barrel.

1 barrel of lime contains about 3.6 cubic feet.

A bricklayer's hod will hold 20 bricks or ⅔ cubic foot of mortar.

1000 bricks closely stacked occupy 56 cubic feet.

1000 old bricks, cleaned and loosely stacked occupy 72 cu.ft.

500 bricks make 1 cart load.

To allow for breakage, add 5% to the actual number of bricks needed.

142. Masonry Items. For the purpose of checking masonry work, the following list of material and of parts of the building requiring masonry work are given:

| <i>Materials.</i> | <i>Members.</i> |
|-------------------|------------------|
| Lime | Footings |
| Cement | Foundation walls |
| Sand | Piers |
| Broken stone | Chimneys |
| Gravel | Chimney breasts |

| <i>Materials.</i> | <i>Members.</i> |
|-------------------|-----------------|
| Cut stone: | |
| Granite | Flue linings |
| Bluestone | Area walls |
| Limestone | Cisterns |
| Sandstone | Exterior walls |
| Marble | Partition walls |
| Carved stonework | |
| Brick | |
| Face | |
| Rough | |
| Bolts and anchors | |
| Labor | |

143. Arrangement of Estimating Sheet. The masonry estimating sheet should be arranged as follows:

2. Masonry.

Concrete Footings: 1 : 3 : 5 Portland cement, sharp sand, and 2" broken stone; in forms.

| | | |
|-------------------------|------------------------------|---------------------------|
| Side walls..... | 30' 0" × 2' 0" × 1' 0" × 2 = | 120 cu.ft. |
| Front and rear walls... | 25' 0" × 2' 0" × 1' 0" × 2 = | 100 " |
| Chimney..... | 4' 6" × 1' 0" × 1' 0" = | 5 " |
| Piers..... | 1' 6" × 1' 6" × 1' 0" × 3 = | 7 " |
| | | 232 cu.ft @ 27¢ = \$..... |

Foundation Walls: Rubble stone in Rosendale cement 1 : 3; up to grade.

| | | |
|-----------------|--------------------------|----------------------------|
| Side wall..... | 24' 0" × 1' 6" × 4' 4" = | 156 cu.ft. |
| Side wall..... | 28' 0" × 1' 6" × 4' 4" = | 182 " |
| Front wall..... | 27' 0" × 1' 6" × 4' 4" = | 176 " |
| Rear wall..... | 27' 0" × 1' 6" × 4' 4" = | 176 " |
| | | 690 cu.ft. @ 22¢ = \$..... |

Brickwork: Rough brick; from grade to underside of first tier of beams; in Portland cement mortar 1 : 3.

| | | |
|-----------------|--------------------------|------------|
| Side wall..... | 28' 0" × 1' 0" × 2' 8" = | 75 cu.ft. |
| Side wall..... | 28' 0" × 1' 0" × 2' 8" = | 75 " |
| Front wall..... | 25' 0" × 1' 0" × 2' 8" = | 67 " |
| Rear wall..... | 25' 0" × 1' 0" × 2' 8" = | 67 " |
| | | 284 cu.ft. |

LESS OPENINGS

| | | |
|-------------|-----------------------------|--------------|
| Window..... | 2' 6" × 1' 6" × 1' 0" × 6 = | 23 cu.ft. |
| Door..... | 3' 0" × 1' 0" × 2' 8" = | 8 " |
| | | 31 cu.ft. 31 |
| | | 253 cu.ft. |

253 × 22½ = 5693 rough brick
59 × 8 = 472 face brick (see below)

Net rough brick..... 5221 + 5% = 5482 or
5500 brick @ \$20 per M. = \$.....

Face brick, in colored cement 1 : 2; running bond.

| | | |
|--------------|------------------|-----------|
| Front..... | 15' 0" × 2' 8" = | 40 sq.ft. |
| Return..... | 4' 0" × 2' 8" = | 11 " |
| Chimney..... | 3' 0" × 2' 8" = | 8 " |

59 sq.ft.

Face brick 59 × 8 (brick per sq.ft.) = 472 brick @ \$60 per M. = \$.....\$.....

(Again the student is cautioned to obtain local prices for the various items above enumerated. The prices here quoted are simply illustrative.)

(C) PLASTERING

The square yard is the unit of measure by which plastering is estimated. There is no uniform rule regarding allowances for "outs," i.e., door and window openings. In some localities, no deductions are made; in others, one-half the area of the openings is deducted; while in

still others, only openings of a specified area are deducted. The student should, therefore, make inquiries regarding the practice obtaining in his locality.

In taking off quantities for plastering, measure each room separately, arrange them categorically, floor by floor, and reduce the measurements to square feet of wall surface as the dimensions of each room are set down. Then compute the number of square feet of "outs," and deduct this amount from the total number of square feet of plastering before reducing to square yards.

Some of the more common practices in taking off quantities for plastering are the following:

- (1) Pilasters and all strips less than 12" wide are measured 12".
- (2) For closets, add one-half to the actual dimensions.
- (3) Charge a double price for all circular or elliptical work.
- (4) Figure cornices by the square foot if they are composed of plain members, and by the lineal foot if they are composed of enriched moldings.
- (5) Add 5% for each 12' in height above the first 12', on interior work, and 1% for each 20' in height above the first 20', on exterior work.

144. Estimating Data. Lathing. Laths are put up in bundles of 50 or 100. To cover 100 square yards, 1500 laths and 10 pounds of 3d finishing nails are required. Under ordinary circumstances a man should lath 100 square yards per day.

Plaster. To cover 100 square yards, the following quantities are needed; for 3-coat work, 2 cubic yards of sand, 2 bushels of hair, 12 bushels of lime, and 100 pounds of plaster of Paris. For 2-coat work, 10 bushels of lime, 1½ bushels of hair and 1½ cubic yards of sand are required.

Two plasterers and one helper should average 45 square yards of 3-coat plastering or about 65 square yards of 2-coat.

Given the above figures, the student should have little difficulty in computing the price per 100 square yards of plastering once he has obtained the rate of wages and the price of plasterer's supplies.

145. Arrangement of Estimate Sheet. Arrange the plastering estimate sheet as follows:

3. Plastering. 3-coat work on spruce lath.

| | | | |
|---------------------|--|---------------------|-------------|
| <i>Living Room.</i> | Walls..... | 57' 0" × 9' 0" = | 513 sq.ft. |
| | Ceiling..... | 14' 0" × 14' 6" = | 203 " |
| <i>Dining Room.</i> | Walls..... | 48' 0" × 9' 0" = | 432 " |
| | Ceiling..... | 12' 0" × 12' 0" = | 144 " |
| Etc. | | | 1292 sq.ft. |
| | Deductions: | | |
| | | 8' 0" × 7' 0" × 2 = | 112 |
| | | 6' 6" × 7' 0" = | 46 |
| | | 6' 0" × 5' 0" = | 30 |
| | | 5' 0" × 4' 0" = | 20 |
| | | | 208 |
| | | | 1084 sq.ft. |
| | Total plastering 1084 ÷ 9 = 121 sq.yds. @ 50¢ per sq.yd. = \$..... | | |

(D) CARPENTRY

Lumber is calculated by the foot, board measure. A *board foot* is a piece of lumber 1 foot long, 1 foot wide, and 1 inch thick. To find the number of board feet in any piece of timber divide the sectional area in inches by 12 and multiply the quotient by the length in feet. Thus, a 2" × 9" floor joist, 18 feet long, contains

$$\frac{2 \times 9}{12} \times 18 = 27 \text{ ft. B.M.}$$

The following table shows at a glance the number of board feet contained in stock lumber from 2" × 4" to 14" × 16", from 10' to 32' in length.

TABLE OF BOARD MEASURE

| Size in Inches. | Length in Feet. | | | | | | | | | | | |
|-----------------|-----------------|-----|------|------|-----|------|------|-----|------|------|-----|------|
| | 10 | 12 | 14 | 16 | 18 | 20 | 22 | 24 | 26 | 28 | 30 | 32 |
| 2×4 | 6½ | 8 | 9½ | 10½ | 12 | 13½ | 14½ | 16 | 17½ | 18½ | 20 | 21½ |
| 2×6 | 10 | 12 | 14 | 16 | 18 | 20 | 22 | 24 | 26 | 28 | 30 | 32 |
| 2×8 | 13½ | 16 | 18½ | 21½ | 24 | 26½ | 29½ | 32 | 34½ | 37½ | 40 | 42½ |
| 2×10 | 16½ | 20 | 23½ | 26½ | 30 | 33½ | 36½ | 40 | 43½ | 46½ | 50 | 53½ |
| 2×12 | 20 | 24 | 28 | 32 | 36 | 40 | 44 | 48 | 52 | 56 | 60 | 64 |
| 2×14 | 23½ | 28 | 32½ | 37½ | 42 | 46½ | 51½ | 56 | 60½ | 65½ | 70 | 74½ |
| 2×16 | 26½ | 32 | 37½ | 42½ | 48 | 53½ | 58½ | 64 | 69½ | 74½ | 80 | 85½ |
| 2½×12 | 25 | 30 | 35 | 40 | 45 | 50 | 55 | 60 | 65 | 70 | 75 | 80 |
| 2½×14 | 29½ | 35 | 40½ | 46½ | 52½ | 58½ | 64½ | 70 | 75½ | 81½ | 87½ | 93½ |
| 2½×16 | 33½ | 40 | 46½ | 53½ | 60 | 66½ | 73½ | 80 | 86½ | 93½ | 100 | 106½ |
| 3×6 | 15 | 18 | 21 | 24 | 27 | 30 | 33 | 36 | 39 | 42 | 45 | 48 |
| 3×8 | 20 | 24 | 28 | 32 | 36 | 40 | 44 | 48 | 52 | 56 | 60 | 64 |
| 3×10 | 25 | 30 | 35 | 40 | 45 | 50 | 55 | 60 | 65 | 70 | 75 | 80 |
| 3×12 | 30 | 36 | 42 | 48 | 54 | 60 | 66 | 72 | 78 | 84 | 90 | 96 |
| 3×14 | 35 | 42 | 49 | 56 | 63 | 70 | 77 | 84 | 91 | 98 | 105 | 112 |
| 3×16 | 40 | 48 | 56 | 64 | 72 | 80 | 88 | 96 | 104 | 112 | 120 | 128 |
| 4×4 | 13½ | 16 | 18½ | 21½ | 24 | 26½ | 29½ | 32 | 34½ | 37½ | 40 | 42½ |
| 4×6 | 20 | 24 | 28 | 32 | 36 | 40 | 44 | 48 | 52 | 56 | 60 | 64 |
| 4×8 | 26½ | 32 | 37½ | 42½ | 48 | 53½ | 58½ | 64 | 69½ | 74½ | 80 | 85½ |
| 4×10 | 33½ | 40 | 46½ | 53½ | 60 | 66½ | 73½ | 80 | 86½ | 93½ | 100 | 106½ |
| 4×12 | 40 | 48 | 56 | 64 | 72 | 80 | 88 | 96 | 104 | 112 | 120 | 128 |
| 4×14 | 46½ | 56 | 65½ | 74½ | 84 | 93½ | 102½ | 112 | 121½ | 130½ | 140 | 149½ |
| 6×6 | 30 | 36 | 42 | 48 | 54 | 60 | 66 | 72 | 78 | 84 | 90 | 96 |
| 6×8 | 40 | 48 | 56 | 64 | 72 | 80 | 88 | 96 | 104 | 112 | 120 | 128 |
| 6×10 | 50 | 60 | 70 | 80 | 90 | 100 | 110 | 120 | 130 | 140 | 150 | 160 |
| 6×12 | 60 | 72 | 84 | 96 | 108 | 120 | 132 | 144 | 156 | 168 | 180 | 192 |
| 6×14 | 70 | 84 | 98 | 112 | 126 | 140 | 154 | 168 | 182 | 196 | 210 | 224 |
| 6×16 | 80 | 96 | 112 | 128 | 144 | 160 | 176 | 192 | 208 | 224 | 240 | 256 |
| 8×8 | 53½ | 64 | 74½ | 85½ | 96 | 106½ | 117½ | 128 | 138½ | 149½ | 160 | 170½ |
| 8×10 | 66½ | 80 | 93½ | 106½ | 120 | 133½ | 146½ | 160 | 173½ | 186½ | 200 | 213½ |
| 8×12 | 80 | 96 | 112 | 128 | 144 | 160 | 176 | 192 | 208 | 224 | 240 | 256 |
| 8×14 | 93½ | 112 | 130½ | 149½ | 168 | 186½ | 205½ | 224 | 242½ | 261½ | 280 | 298½ |
| 10×10 | 83½ | 100 | 116½ | 133½ | 150 | 166½ | 183½ | 200 | 216½ | 233½ | 250 | 266½ |
| 10×12 | 100 | 120 | 140 | 160 | 180 | 200 | 220 | 240 | 260 | 280 | 300 | 320 |
| 10×14 | 116½ | 140 | 163½ | 186½ | 210 | 233½ | 256½ | 280 | 303½ | 326½ | 350 | 373½ |
| 10×16 | 133½ | 160 | 186½ | 213½ | 240 | 266½ | 293½ | 320 | 346½ | 373½ | 400 | 426½ |
| 12×12 | 120 | 144 | 168 | 192 | 216 | 240 | 264 | 288 | 312 | 336 | 360 | 384 |
| 12×14 | 140 | 168 | 196 | 224 | 252 | 280 | 308 | 336 | 364 | 392 | 420 | 448 |
| 12×16 | 160 | 192 | 224 | 256 | 288 | 320 | 352 | 384 | 416 | 448 | 480 | 512 |
| 14×14 | 163½ | 196 | 228½ | 261½ | 294 | 326½ | 359½ | 392 | 424½ | 457½ | 490 | 522½ |
| 14×16 | 186½ | 224 | 261½ | 298½ | 336 | 373½ | 410½ | 448 | 485½ | 522½ | 560 | 597½ |

In obtaining an estimate of the carpentry work, the following three divisions are suggested: (a) lumber; (b) mill work; and (c) labor. Each of these has further subdivisions, which will be taken up in due order.

146. Lumber. The items included under this heading are as follows:

| | |
|-----------------|-------------------|
| Sills | Lookouts |
| Girders | Collar beams |
| Posts | Studding—Outside |
| Girts | Partition |
| Braces | Furring |
| Joists—Basement | Grounds |
| First Floor | Sheathing |
| Etc. | Siding |
| Bridging | Shingles |
| Plates | Building paper |
| Rafters—Common | Flooring—finished |
| Hip | under |
| Valley | |
| Jack | |

(Of course, the above list does not comprise every possible item. However, a sufficient number of examples are given under each heading to allow one to recognize and properly classify any item not mentioned above.)

Beginning with the girders and following in the order of erection with sills, posts, joists, studs, etc., the number of board feet is computed in each member and itemized as shown below. The total number of board feet is obtained, and this number is multiplied by the prevailing price of lumber per 1000 feet, board measure. A foot, board measure, is represented by the symbol \perp ; a square foot, by \square .

| | | |
|---|--------|-----------------------|
| 4, 6"×8"×8' 0" girders | =128⊥ | |
| 3, 6"×6"×6' 0" posts | = 54⊥ | |
| 46, 2"×8"×12' 0" first floor beams | =736⊥ | |
| 8, 6"×6"×14' 0" sills | =336⊥ | |
| Etc., etc. | | |
| Total feet framing lumber |⊥ | @ \$38 per M. = |
| 8000 shingles, red cedar, perfection, 5"×18" | | @ \$5 per M. = |
| 2000 □ first floor flooring, 1/4"×2 1/4", N.C.T. & G. | | @ \$45 per M. □ = ... |
| Etc. etc. | | |
| Total lumber bill | | \$..... |

147. Mill Work. Mill work embraces all finished lumber, that is, all lumber that has to be run through machines. This second part of the carpentry estimate lends itself to two divisions: exterior mill work and interior mill work. Some of the items included under each division are given below:

(1) *Exterior Finish.*

- Window frames
 - sash
 - glazing
 - blinds
- Door frames
- Porch rail
 - balusters
 - newels
- Cornices
- Corner boards
- Belt courses
- Water table

(2) *Interior Finish.*

- Doors—sliding
 - folding
- Window stops
 - stools
- Casings
- Book cases
- Mantels
- Medicine case
- Shelving
- Floor mold, chair-rail, wainscoting, picture molding, etc.

The stock bill for mill work should be drawn up in the same careful manner as that outlined for the lumber bill. Every item taken off should be checked and constantly verified.

| | |
|---|-----------|
| 27 Windows, complete, with hardware, 30"×28", 6 lts. upper sash, 1 lt. lower sash, @ \$14 | = \$..... |
| 4 Entrance and vestibule doors, oak, complete 3' 0"×7' 0"×1 1/4" @ \$30 | = \$..... |
| 1 Medicine case, oak, glass shelving | \$..... |
| Picture molding, 1/4"×1 1/4", oak, 1200 lin.ft. @ 5 cts. | = \$..... |
| Etc., etc. | |
| Total mill work | \$..... |

148. Labor. Labor is figured by the square foot in some cases, by the lineal foot in others, and by the piece in still other instances.

| | | |
|----------------------------|----------------------------|----------------------|
| <i>By the Square Foot.</i> | <i>By the Lineal Foot.</i> | <i>By the Piece.</i> |
| Flooring | Cornices | Stairs |
| Walls | Belt courses | Mantels |
| Roofing | Porch rails | Closets |
| Sheathing | Inside trim | Columns, etc. |
| Siding | | |
| Shingling | | |

The authors suggest the following scheme in arranging prices of materials and labor for the carpentry estimate.

| | Material. | | Labor. | |
|--|--------------|------------|---------|-----------|
| | | | | |
| 50—3"×12"×12'0", Y.P.S.L. Floor beams | 1800 ⊥ | \$35.00 M. | \$63.00 | \$20 M. |
| 1"×2", Spruce Bridging | 1000 lin.ft. | 50¢ | 5.00 | 1¢ l.ft. |
| 1/4"×2 1/4", N.C.T. & G. | | | | |
| Flooring | 2000 □ | \$45.00 M. | 90.00 | 2¢ sq.ft. |
| Best Cypress Shingles | 8000 | \$5.00 M. | 40.00 | 6.00 M. |
| Etc. etc. | | | | |
| Total material, cost..... | | | \$..... | |
| Total labor, cost..... | | | | \$..... |

149. Estimating Data. Beams. To find the number of beams, divide the length of the building in feet by the distance (also in feet), the beams are placed on centers, and add one joist. Rafters are calculated in the same manner.

About 850 feet, board measure, of common sized joists can be framed and set in one day by two carpenters working together. A conservative estimate of the number of rafters that can be laid by two men in one day would be 500 feet if the roof is plain; i.e., if it is not cut into by dormers, hips, etc.

About 22 pounds of 10d nails are needed per 1000 feet of beams or rafters.

Bridging. To illustrate the method of calculating the number of board feet of bridging required, let us assume a house 25' wide and 50' deep. Since bridging is placed 8 feet apart, two rows of double bridging are needed. Therefore 50×4 , or 200, will give the number of lineal feet; multiplying this by $\frac{1}{2}$, if the bridging is 2×3 inches will give the number of board feet; to this must be added 20% for waste in cutting and fitting.

One man can put in place 500 lineal feet of 2"×3" bridging per day.

Studding. To arrive at the quantity of studs, take the outside measurements of the building and allow one stud for each lineal foot. This method of computing provides for the doubling of studs at corners, doors, and windows. If the studs for partitions are calculated in the same manner, that is, one stud for each foot in length, no extra studs need be allowed for partition plates at the top and bottom.

Two workmen can frame and put up from 600 to 700 feet of studding per day. One thousand feet of studding require about 15 pounds of 10d nails.

Sheathing. Sheathing is estimated by the *square*, i.e., by the 100 square feet. To find the quantity of horizontal sheathing required, calculate the area of all surfaces (walls and roofs) covered, allowing nothing for openings. If diagonal sheathing is used, proceed as above and add 10% for waste in sawing both ends. When estimating for roof surfaces, add 25% to the actual area to be covered.

Two men will average 10 squares of horizontal sheathing

and 8 squares of diagonal sheathing per day. Only half the former amount can be accomplished when applying sheathing on roofs, particularly if the layout is complex. About 25 pounds of 10d nails will be needed for 1000 feet of sheathing.

Flooring. Flooring is estimated by the square or by the thousand square feet. Considerable material is consumed in cutting tongues and grooves in the boards. Therefore, to arrive at the amount of finished flooring required for a given room, multiply its width in feet by its length in feet, and add the following percentages:

50% for $1\frac{3}{8}$ "× $1\frac{1}{2}$ " flooring;
37½% for $1\frac{3}{8}$ "×2" flooring;
33½% for $1\frac{3}{8}$ "× $2\frac{1}{4}$ " flooring.

An average day's work for two carpenters is 4 squares of matched flooring or about twice that amount of square edged flooring. Approximately, 35 pounds of 10d nails are needed per square.

Siding. Obtain the gross superficial area, making no allowance for openings and add the following percentages for waste:

25% if 6" siding is used and
33½% if 4" siding is used.

To the cost of 1000 square feet of siding must be added the cost of 1000 square feet plus 10% of building paper, and 18 pounds of 6d nails.

Two men should set up complete from 600 to 650 board feet of siding.

The above method of figuring includes labor and material for corner boards, and belt courses.

Shingles. Assuming one side of a house to be 25'×30', the number of square feet will be 750; subtracting the "outs" which we will assume to be 150, the net surface to be covered will be 600 square feet; figuring 5 shingles to the foot, 3000

will be needed; allowing 5% for waste, gives 3150, the total number of shingles required to cover the given surface.

Therefore to calculate the number of shingles required, find the area of the surface to be covered, deduct the "outs" or openings, and allow 5 shingles to the square foot; to this result add 5% for waste. One thousand shingles require 5 pounds of 4d nails. One man can lay 2000 shingles per day.

For other methods of estimating quantities and labor the student is referred to "Roof Shingles," paragraph 99.

Doors and Windows. Assume a typical window and figure it complete in every detail: frame, sash, weights, cord, etc.; also, labor on all these items. Having ascertained the cost of one window, multiply it by the number of windows in the building. Proceed in the same manner with doors. It is advisable to make all doors and windows of stock size, for not only does that decrease the cost, but estimating is greatly facilitated thereby.

As an aid to the student in arriving at prices, the following analyses of a door and a window are given:

| <i>Window 3'×6'</i> | | <i>Door 2', 8"×6', 8"×1½"</i> | |
|-----------------------------|---------|-------------------------------|---------|
| Window frame..... | \$ 6.00 | Door, pine..... | \$10.00 |
| Sashes (3'×6': double hung) | 4.00 | Frame..... | 1.00 |
| Blinds (2)..... | 2.50 | Jamb..... | 1.00 |
| Blind fastenings..... | .25 | Casings..... | 2.00 |
| Weights (30 pounds)..... | .90 | Saddle..... | .40 |
| Sash cord (20 feet)..... | .50 | Nails..... | .10 |
| Sash fasteners..... | .25 | Hardware..... | .80 |
| Jamb (16 feet)..... | .48 | Labor 10 hours.. | 6.25 |
| Inside casing (16 ft.)..... | 1.28 | | |
| Stop bead..... | .30 | Total cost.... | \$21.55 |
| Labor, 12 hours..... | 7.50 | | |
| | | | |
| Total cost..... | \$23.96 | | |

The student should acquaint himself with actual prices current in his particular locality and change or insert the figures to suit.

One man can do the following:

1. He can set, glaze, put on hardware, fit, weigh sash and hang the weights of an ordinary size window (3'×6', 4 lights) in 1½ days.
2. He can frame, install jambs, trim, fit and hang one interior door in 1¼ days; one sliding door in 2¼ days; and one front door in 2 days.
3. He can set up 50 feet of three-member base per day, including grounds; 80 feet of two-member base; or 120 ft. of one-member base.

Two men can install complete 1 wardrobe or 1 kitchen dresser (4 ft. wide by 9 ft. high) in one day.

Stairs. Estimate in detail the cost of one step (riser, tread, nosing, carriage, string, handrail, baluster and labor for cutting, housing, setting and finishing same), and multiply by the number of steps in the flight.

Front stairs cost from \$4 to \$5 per step; rear stairs from \$2 to \$3 per step; and cellar stairs from 85¢ to \$1 per step. Of course these prices are not stationary; nor do they obtain in all localities. Any local stair contractor will gladly furnish the student current prices of the above items.

Cornice. The method recommended to the student in figuring the cost of a cornice, is this: Allow one cent per lin al foot for each inch in width or girth of cornice; this price will include all labor and material.

(It can not be too often repeated that prices of labor and material herein given are used for purposes of illustration and are not to be taken as standard.)

(E) ROOFING

Roofing is estimated by the square which is equal to 100 square feet.

150. Slate Roof. Slates are laid with a lap of 3 inches, i.e., the top slate of the third course above will overlap by 3 inches the slate of the first course below. Each slate is fastened in place with two nails, one in each upper corner.

TABLE
SHOWING SIZES OF SLATES, THE NUMBER OF PIECES IN A SQUARE, AND THE GAUGE, ALLOWING 3 INCHES LAP

| Size of Slate (Inches). | No. in each Square. | Length of Exposure to the Weather. |
|-------------------------|---------------------|------------------------------------|
| 12× 6 | 533 | 4½ |
| 12× 7 | 457 | 4½ |
| 12× 8 | 400 | 4½ |
| 14× 7 | 374 | 5½ |
| 14× 8 | 327 | 5½ |
| 14×10 | 261 | 5½ |
| 16× 8 | 277 | 6½ |
| 16× 9 | 247 | 6½ |
| 16×10 | 222 | 6½ |
| 16×12 | 185 | 6½ |
| 18× 9 | 214 | 7½ |
| 18×10 | 192 | 7½ |
| 18×12 | 160 | 7½ |
| 20×10 | 170 | 8½ |
| 20×12 | 142 | 8½ |
| 22×11 | 138 | 9½ |
| 22×12 | 126 | 9½ |
| 24×12 | 115 | 10½ |
| 24×14 | 98 | 10½ |

To determine the number of slates required to cover one square, divide 14,400 by the exposed area of one slate. The latter is obtained by subtracting the lap (3") from the length of the slate, dividing by 2, and multiplying by the width of the

slate. Thus, a 10"×16" slate has a "gauge" or an exposed length of $\frac{16-3}{2}=6\frac{1}{2}"$, which, multiplied by 10 equals 65, the area of the exposed surface; this area divided into 14,400, will give 222, the required number of slates for one square. An allowance of about 20% should be made for waste in cutting around chimneys, hips, etc. The number of nails will be twice the number of slates used. Slates up to and including 20", should be secured with 3d nails; larger sizes should have 4d nails. One roll of tar paper will cover one square of roofing surface. A man should lay one square of slate roofing, complete, in about five hours.

151. Shingle Roof. Shingles are estimated by the thousand. They usually come in 4-inch and 6-inch widths and are 16 or 18 inches long. They are put up in bundles of 250.

To illustrate the manner of calculating the quantity of shingles required per square: A shingle 4" wide laid 4½" to the weather will cover 18 square inches. A square contains 14,400 square inches, hence dividing this by 18 will give 800. Add 5% for poor or broken shingles. About 5 pounds of 4d nails will secure 1000 shingles. From 1500 to 2000 shingles per day would constitute a fair day's work when the surface is plain and 1000 shingles if the surface is cut up.

TABLE
NUMBER OF SHINGLES PER SQUARE
(Length of shingles 16")

| To the Weather. | Number per Square. | Covering Capacity of M. Shingles. |
|-----------------|--------------------|-----------------------------------|
| 4 | 900 | 111 |
| 4½ | 800 | 125 |
| 5 | 720 | 139 |
| 6 | 600 | 167 |
| 7 | 514 | 194 |
| 8 | 450 | 222 |

The above figures are for plain gable roofs; for hip roofs or those having many dormers and valleys, add 5% to the above quantities in addition to the 5% for poor or broken shingles.

152. Tin Roof. The standard sizes of tins are 10"×14" and multiples thereof, e.g., 14×20, 20×28, etc. Tins are laid with 1" laps; therefore, in finding the area of roof surface covered by a 10"×14" tin, for instance, deduct one inch from the length and the breadth and proceed in the same manner as described under shingle roofing in ascertaining the number of sheets needed to cover a square.

One box of tin contains 112 sheets (14"×20") and will cover 182 square feet of surface if standing seams are used, and 192 square feet if lock seams are used.

Two men working eight hours should cover from 2½ to 3 squares of roofing per day, depending upon the character of the surface tinned. To the cost of labor must be added the following: 8 pounds solder, 2 pounds nails, 1 pound rosin, and 1 roll paper or felt, per square —.

Gutters and spouts are measured by the lineal foot; flashing by the square foot.

(F) MECHANICAL EQUIPMENT

In estimating the mechanical equipment of a building (plumbing, gas-piping, wiring, heating, and hardware), the contractor usually requests bids from experts in their respective lines of work and uses the figures submitted as a basis in arriving at the total cost of the entire contract. The suggestions given below are for that reason of the most general charac-

ter and should be used in obtaining only very rough estimates.

153. Plumbing. Plumbing fixtures of the same quality and used for the same purpose will evidently cost the same per fixture if used in the same type of house whether installed in a building of four stories or in one of ten stories. Hence, by obtaining from a local contracting plumber the cost of installing complete per fixture the particular type of fixture you are bidding on, the question of estimating plumbing reduces itself to one of simple addition and multiplication. The work of taking off the quantity of fixtures needed is considerably lessened if the specifications contain a schedule of fixtures. See "Fixtures," article 128.

Plumbing, that is material and labor, costs from 8 to 10% of the cost of an ordinary dwelling. On a basis of 100, 30 would represent labor and 70, stock.

154. Piping and Wiring Approximate estimates for piping for gas and of wiring for incandescent lights may be based upon the number of outlets, the price of which any contractor will gladly furnish.

The cost of piping, without the fixtures, is from 2 to 4% of the cost of the building.

155. Heating. A hot-air system cost approximately from 6 to 7% of the total expenditure for the ordinary class of house; from 8 to 10% if a steam heating system is employed; and from 10 to 12% if a hot water system is installed.

156. General. The layout or arrangement of the plumbing work affects to a considerable extent the cost of the mechanical equipment of a building. The cost of installing a sink, for instance, on the third floor, would be less if it comes directly over another sink on the second floor, than if both fixtures were in entirely different parts of the house. For, in the latter case two waste and two vent pipes would be required, while in the

former case one waste and two short vents would suffice. Similarly, in the case of wiring and gas fitting, a number of outlets in close proximity would cost less per outlet than if they were widely separated. The cost of wiring would be affected by the manner of running the wires, whether through conduits, or by the knob and tube method. These instances are cited merely to show the complicated character of the subjects at hand and the rashness of going into further detail in their discussion.

(G) **HARDWARE**

Referring to the specifications for quality and finish, to the plans for quantity, and to the catalogue of a reputable firm (the name of which is usually specified) for net prices, the various hardware items are taken off, the cost figured, and an estimate obtained. Any errors that may occur will be found due not so much to calculation as to omission. It is therefore recommended that a complete list of all the hardware trimmings that usually enter into the equipment of a house be prepared and that the list be constantly referred to and checked as a precaution against probable omission.

157. Estimating Data. Below is given a list of hardware items which may be used as a guide in preparing an estimate.

| | |
|--------------------|------------------|
| Closets. | Windows. |
| Coat and hat hooks | Sash fasts |
| Shelf brackets | Sash cords |
| Drawer pulls | Sash weights |
| Catches | Sash lifters |
| | Transom fixtures |

| | |
|----------------------|----------------|
| Doors. | Miscellaneous. |
| Knobs | Nails |
| Escutcheons | Screws |
| Locks | Bolts |
| Butts | Clothes hooks |
| Hinges | |
| Bolts | |
| Sliding door hangers | |
| Letter plates | |
| Push plates | |
| Spring and catches | |

Hardware will average about 2% of the total cost of the building. Labor may be reckoned at one-fifth the cost of the materials.

NUMBER OF NAILS REQUIRED

| | | |
|--|--------|---------------------|
| 1000 Shingles..... | 3½ lb. | 3d |
| 1000 Laths..... | 6½ lb. | 3d fine nails. |
| 1000 sq.ft. Beveled siding 6"..... | 18 lb. | 6d |
| 1000 sq.ft. Sheathing..... | 20 lb. | 8d |
| 1000 sq.ft. Flooring..... | 30 lb. | 8d |
| 1000 sq.ft. Studding..... | 15 lb. | 10d |
| 1000 sq.ft. Furring (1"×2")..... | 10 lb. | 10d |
| 1000 sq.ft. Finished flooring (¾")..... | 30 lb. | 8d finishing nails. |
| 1000 sq.ft. Finished flooring (1¼")..... | 40 lb. | 10d " |
| 1000 pieces Bridging 1×4..... | 35 lb. | 8d |
| 1000 pieces Bridging 2×4..... | 50 lb. | 10d |

LENGTH AND APPROXIMATE NUMBER OF NAILS PER POUND

| Size..... | 2d | 3d | 4d | 5d | 6d | 7d | 8d | 9d | 10d | 12d | 16d | 20d |
|------------------|------|-----|-----|-----|-----|-----|-----|-----|-----|-----|-----|-----|
| Length..... | 1" | 1¼" | 1½" | 1¾" | 2" | 2¼" | 2½" | 2¾" | 3" | 3¼" | 3½" | 4" |
| Cut nails..... | 800 | 480 | 288 | 200 | 168 | 124 | 88 | 70 | 58 | 44 | 34 | 23 |
| Wire nails..... | 876 | 568 | 315 | 270 | 180 | 160 | 105 | 96 | 69 | 64 | 49 | 31 |
| Finishing nails. | 1351 | 807 | 584 | 500 | 309 | 238 | 189 | 172 | 121 | 113 | 90 | 62 |

(H) PAINTING AND PAPERING

Painting is estimated by the square yard of surface to be covered. It is customary not to take into account the size of openings in measuring the surface to be covered because the labor required in painting sill, sash, and casing would more than equal the labor required in painting a solid wall.

The price per square yard varies with the kind of paint used, the character of the surface to be covered, and the need if any, of staging. Hardly any two painters use the same method in estimating their work, and no rules can therefore be laid down that will be applicable to all cases. Judgment and practical experience play a greater factor in painting than in any other branch of estimating.

158. Estimating Data. To ascertain the amount of paint needed, add the length in feet of the front, rear, and the two side walls of the house, multiply this sum by the average height and divide by 250. One gallon of prepared paint will cover from 200 to 300 square feet, or an average of 250 square feet of surface, two-coat work. The rougher and more porous the surface the greater will be the amount of paint used.

About one pound of putty for stopping is required for every 175 square feet of surface.

Some contractors figure painting at 1 cent per square foot for every coat applied.

One thousand shingles dipped one coat and brushed one coat require 3 gallons of stain. One gallon may be figured to cover 150 square feet of surface brushed one coat or 100 square feet, brushed two coats.

Labor may be calculated at from 1½ to twice the cost of the stock, depending upon the complexity of the work.

159. Papering. Wall paper may be purchased in double rolls 18" wide and 16 yards long. To find the quantity of paper required measure the perimeter of the room in yards, deduct only openings exceeding 20 square feet and add ¼ for waste in cutting around openings and for matching the pattern of the paper. The number of strips will be double the number of yards. Divide the number of strips required by the number of strips that can be cut from a roll and the result will be the number of rolls required.

160. Summary Sheet. When the student has completed his detailed estimate, he should make up a recapitulation or summary sheet, which should be arranged thus:

SUMMARY

| | |
|------------------------------------|--------------|
| Excavation | \$ |
| Concrete | |
| Stonework | |
| Brickwork | |
| Plastering | |
| Carpentry | |
| Hardware | |
| Tin work | |
| Plumbing and gas fitting | |
| Electric work | |
| Painting | |
| | _____ |
| Total cost | \$ |
| Incidentals, 5% of total | |
| Profit, 10% of total | |
| | _____ |
| Grand total | \$ |

INDEX

| | PAGE | | PAGE |
|------------------------------|-------|--|--------|
| Aggregate | 28 | Bay window | 59 |
| Anchor | 37 | Beams | 45 |
| Approximate estimating: | | estimating | 96 |
| basis of | 88 | in brick walls | 37 |
| methods | 89 | specifications | 79 |
| Arch | 74 | in terra-cotta tile wall | 43 |
| Architectural symbols | 15 | size | 46 |
| Architecture: | | spacing | 46 |
| adaptability | 74 | support | 48 |
| art and science | 1, 71 | tail | 46 |
| definition | 69 | under partitions | 49 |
| mirror of civilization | 73 | Bearing partitions | 49 |
| orders of | 71 | Bearing walls, Portland cement for | 28 |
| Architrave | 64 | Beauty in design | 69 |
| Ashlar | 26 | in decoration | 73 |
| Ash pit | 51 | definition | 74 |
| Axes | 19 | Bells | 85 |
| Balance | 19 | Blocks: | |
| Balloon frame | 48 | concrete | 41 |
| Balusters | 66 | terra-cotta | 30, 42 |
| Baseboard | 64 | Board foot | 94 |
| specifications for | 80 | Boarding, see Sheathing. | |
| Bat | 24 | Bonding: | |
| Batten, see Roof lath. | | angles in brickwork | 36 |
| Batter boards | 32 | brick | 23 |
| | | stone | 38 |

| | PAGE | | PAGE |
|----------------------------------|------------|---------------------------------|--------|
| Box stairs..... | 66 | Casement window..... | 59 |
| Braced frame, see Full frame. | | Cement: | |
| Braces..... | 46, 48, 52 | for concrete..... | 39 |
| Brick: | | kinds..... | 28 |
| common..... | 22 | natural or Rosendale..... | 28 |
| construction..... | 36 | Portland..... | 28 |
| conventions for..... | 15 | specifications..... | 77 |
| face..... | 22 | Chair rail..... | 64 |
| footings..... | 35 | Chimney: | |
| laying..... | 36 | estimating brick for..... | 92 |
| manufacture..... | 22 | flue..... | 50 |
| size..... | 23 | framing for..... | 46 |
| specifications..... | 77 | specifications..... | 79 |
| testing..... | 22 | material for building..... | 50 |
| Brick walls: | | specifications..... | 78 |
| thickness..... | 36 | Clapboard..... | 54 |
| estimating data..... | 92 | specifications..... | 79 |
| Brickwork: | | Closer..... | 24 |
| bonding..... | 23 | Coats of plaster..... | 63 |
| estimating..... | 92 | quantities of material for..... | 94 |
| joints in..... | 23 | specifications..... | 78 |
| pointing..... | 23 | Combination frame..... | 48 |
| specifications..... | 77 | Concrete: | |
| terms..... | 24 | blocks..... | 29, 40 |
| Bridging: | | composition..... | 28 |
| estimating..... | 97 | construction..... | 39 |
| floor..... | 46 | convention for..... | 15 |
| specifications..... | 79 | estimating data..... | 91 |
| wall..... | 49 | mixing, laying..... | 39 |
| Bridle irons, see Stirrup irons. | | reinforced..... | 29, 40 |
| Brushes..... | 4 | specifications..... | 77 |
| Building: | | Conduit..... | 84 |
| details, conventions..... | 17 | Construction: | |
| materials, conventions..... | 15 | frame..... | 45 |
| paper..... | 54 | masonry..... | 31 |
| specifications..... | 79 | materials of..... | 22 |
| stones..... | 24 | Contracts..... | 11 |

| | PAGE |
|---------------------------------|--------|
| Contracts, procedure | 50 |
| Corner board..... | 55 |
| Corner post..... | 46 |
| specifications..... | 79 |
| Cornice: | |
| estimating cost of..... | 98 |
| exterior..... | 53 |
| interior..... | 64 |
| Cost, see Estimating. | |
| Course in brickwork..... | 24 |
| Cubing..... | 89 |
| | |
| Decoration..... | 72 |
| Design..... | 69 |
| divisions of exterior..... | 21 |
| factors in..... | 70 |
| of plan and elevation..... | 9 |
| principles of..... | 19, 21 |
| procedure..... | 10 |
| Detailed estimating..... | 89 |
| Details: | |
| conventions for building..... | 17 |
| definition..... | 9 |
| scale of..... | 4 |
| Dimensioning..... | 13 |
| Dog-legged stairs..... | 66 |
| Door frame, specifications..... | 80 |
| Doors: | |
| design of..... | 72 |
| estimating..... | 98 |
| solid..... | 61 |
| specifications..... | 80 |
| types..... | 61 |
| veneered..... | 59 |
| Dormer..... | 59 |
| Double-hung window, see Window. | |
| Drafting methods..... | 7 |

| | PAGE |
|-----------------------------------|----------------|
| Drawing: | |
| architectural vs. mechanical..... | 1 |
| architectural vs. freehand..... | 2 |
| exhibition..... | 17 |
| instruments..... | 2 |
| moldings..... | 11 |
| preliminary..... | 4, 11 |
| silhouetting..... | 11 |
| working..... | 4, 11 |
| | |
| Earth: | |
| convention for..... | 15 |
| increase in volume..... | 90 |
| Eaves..... | 50 |
| Eave trough, see Gutter. | |
| Elevation: | |
| definition..... | 9 |
| expression..... | 70 |
| plan and design of..... | 10 |
| Estimate: | |
| approximate..... | 88 |
| arrangement of sheet..... | 91, 93, 94, 96 |
| detailed..... | 89 |
| divisions..... | 89 |
| procedure..... | 90 |
| summary..... | 102 |
| Estimating: | |
| carpentry..... | 94 |
| excavation..... | 90 |
| hardware..... | 101 |
| heating..... | 100 |
| masonry..... | 91 |
| painting and papering..... | 102 |
| piping and wiring..... | 100 |
| plumbing..... | 100 |
| roofing..... | 99 |

| | PAGE | | PAGE |
|---|-----------|---|---------------|
| Excavation: | | Foundation wall: | |
| estimating | 90 | definition | 35 |
| size | 33 | materials | 35, 41 |
| specifications | 77 | Portland cement for | 28 |
| Expression: | | thickness | 35 |
| in design | 70 | waterproofing | 31 |
| principles of | 19 | Frame, balloon | 48 |
| technique of | 11 | combination | 48 |
| Exterior finish | 52 | construction | 45 |
| provision for | 45 | door, specification | 80 |
| | | full or braced | 46 |
| | | window, specification | 80 |
| Facade | 9 | Framework | 46 |
| Fenestration | 71 | Framing around chimney | 51 |
| Finish: | | specifications | 79 |
| exterior | 52 | Freehand drawing, see Drawing. | |
| specifications | 79 | French windows | 59 |
| interior | 61 | Fresh-air inlet | 82 |
| specifications | 80 | Full frame | 46, 48 |
| standing, see Trim. | | Furring brick walls | 37 |
| stucco | 57 | plaster, for | 63 |
| Fireplace | 51 | strips | 56 |
| Fixtures, plumbing | 83 | terra-cotta | 43 |
| electrical | 84 | | |
| Flashing | 55 | Gable roof | 54 |
| Flight of stairs | 65 | Gambrel roof | 54 |
| Floor beams, see Beams. | | Gas fittings | 83 |
| Flooring, estimating | 97 | Geometrical stairs | 67 |
| kinds | 64 | Girders | 45 |
| specifications | 80 | Girts | 48 |
| Flue | 50 | specifications | 79 |
| specifications | 78 | Glazing | 81 |
| Footings: | | Granite | 24 |
| purpose | 33 | Grounds | 63 |
| materials for; sizes of | 35 | Gutters | 52 |
| Fore-and-aft partition | 49 | specifications | 100 |
| Forms for concrete | 39 | | |

| | PAGE | | PAGE |
|--------------------------------|--------|---|-------|
| Handrail | 66 | Leaders | 52 |
| Hardware | 80 | specifications | 82 |
| estimating | 101 | Lean-to roof | 53 |
| Headroom | 68 | Ledge | 51 |
| Headers: | | Ledged door; ledged and braced door | 61 |
| brick | 24 | Ledger board, see Ribboh. | |
| wood | 46 | Lime, specifications | 77 |
| specifications | 79 | Limestone | 24 |
| Heating: | | natural cement | 28 |
| estimating | 100 | Lintel | 74 |
| specifications | 85 | Mansard roof | 54 |
| Hip roof | 54 | Marble | 26 |
| House sewer; drain | 81 | Masonry: | |
| Ink, slab | 4 | estimating | 91 |
| stick of India | 4 | walls; materials and thickness | 36 |
| Inking, on tracing cloth | 5 | Materials: | |
| order of | 11 | key to building | 15 |
| Interior finish | 61 | Mechanical drawing: | |
| Iron, see Steel. | | architecture versus | 1 |
| Joints in brickwork | 23 | characteristics | 1, 11 |
| specifications | 77 | faculties developed | 2 |
| stonework | 26 | Mechanical equipment | 100 |
| Joists, see Beams. | | Moldings | 71 |
| Key, plaster | 61 | profiles | 11 |
| to materials | 15 | Mortar, kinds | 28 |
| Landing | 67 | quantities per 1000 brick | 92 |
| Lath: | | specifications | 77 |
| estimating | 94 | Mullions | 59 |
| metal | 56 | Nails | 101 |
| specifications | 78 | Newel | 66 |
| roof | 52 | Non-bearing partitions | 49 |
| specifications | 79 | Nosing | 65 |
| size of wood | 61 | Open-newel stair | 67 |
| specifications | 78 | Orders of architecture | 71 |
| wood | 56, 61 | Ornament, see Decoration. | |

| | PAGE | | PAGE |
|---|------|---|---------|
| Painting: | | Plate rack | 64 |
| estimating | 102 | Plumbing, estimating | 100 |
| specifications | 80 | specifications | 81 |
| Paneled doors | 61 | Pointing | 23 |
| Paper: | | Principles of design | 70 |
| building | 54 | Proportion | 71 |
| damp-proof, for walls | 65 | | |
| Manila | 6 | Radiators | 86 |
| tracing | 5 | Rafters | 46 |
| waterproof, for roofs | 52 | estimating | 96 |
| Whatman's | 6 | kinds | 50 |
| Papering | 102 | Rendering equipment | 4 |
| Partitions, kinds | 49 | rules | 13 |
| estimating studs for | 97 | methods | 14, 15 |
| specifications | 79 | Ribbon | 48 |
| terra-cotta tile | 43 | Ridge | 50 |
| Pencils | 4 | Rise of, roof | 53 |
| Perch | 91 | step | 65 |
| Piers, cellar | 45 | Riser | 65 |
| structural principle | 74 | Roof, estimating materials for | 99, 100 |
| Piles | 35 | finish | 52 |
| Pipes, heating | 86 | framing | 49 |
| plumbing | 82 | lath | 52 |
| Piping for gas, estimating | 100 | sheathing, estimating | 97 |
| Pitch | 53 | terms | 53 |
| Plans, definition | 7 | terra-cotta tile | 43 |
| elevation and, design of | 9 | types | 53, 54 |
| expression of | 70 | Rooms, arrangement | 31 |
| Plaster: | | Rubble, kinds | 26 |
| coats of | 63 | walls, estimating | 91 |
| conventions for | 15 | Run of, roof | 53 |
| estimating | 93 | stair | 65 |
| exterior | 55 | | |
| interior | 63 | Sand, specifications | 77 |
| ornamental | 63 | Sandstone | 24 |
| specifications | 78 | Sash, see Window; specifications | 80 |
| Plate | 46 | Scale, definition | 2 |

INDEX

109

| | PAGE | | PAGE |
|------------------------------------|--------|---|--------|
| Scale of drawings and details..... | 4, 11 | Square foot of floor area, estimating by..... | 89 |
| Sections, building materials..... | 15 | Squared stone..... | 26 |
| definition; kinds..... | 9 | Stability..... | 20 |
| Sheathing, estimating..... | 97 | Staircase..... | 65 |
| floors..... | 45 | Stairs, arrangement..... | 67 |
| roofs..... | 52 | classification..... | 66 |
| specifications..... | 79 | construction..... | 68 |
| Shingles, estimating quantity..... | 97, 99 | estimating..... | 98 |
| exterior covering..... | 55 | layout..... | 67 |
| laying..... | 52 | terms..... | 65 |
| painting..... | 81 | Stairway..... | 65 |
| specifications..... | 79 | Stairwell..... | 65 |
| Siding, estimating..... | 97 | framing..... | 46 |
| kinds..... | 54 | Steel and iron specifications..... | 78 |
| Sill..... | 45 | Step..... | 65 |
| specifications..... | 79 | Stirrup-iron..... | 46 |
| Site..... | 31, 88 | Stone, broken, specifications for..... | 77 |
| Size of framing timbers..... | 79 | conventions..... | 15 |
| Sketches..... | 10 | footings..... | 35 |
| Slate..... | 99 | kinds..... | 26 |
| Soil pipe..... | 82 | terra-cotta as substitute for..... | 43 |
| Specifications: | | walls, thickness..... | 36 |
| aid to estimating..... | 90 | Stonework..... | 24 |
| brickwork..... | 77 | estimating..... | 91 |
| carpentry..... | 79 | Straight run stairs..... | 66 |
| definition..... | 9 | Stretcher..... | 24 |
| electrical..... | 84 | Stretching tracing paper..... | 5 |
| general conditions..... | 76 | Whatman's paper..... | 6 |
| glazing..... | 81 | Strings..... | 66 |
| hardware..... | 80 | kinds..... | 68 |
| heating..... | 85 | Stucco..... | 55, 57 |
| masonry..... | 77 | Studs..... | 46 |
| object..... | 75 | double, for openings..... | 48 |
| order of writing..... | 75 | estimating..... | 97 |
| painting..... | 80 | Style, definition..... | 74 |
| plumbing..... | 81 | structure principles..... | 74 |
| steel and iron..... | 77 | Switch, electrical..... | 84 |

| | PAGE | | PAGE |
|-------------------------------|------|--|--------|
| Tail-beams..... | 46 | Veneered doors..... | 59 |
| specifications..... | 79 | specifications..... | 80 |
| Terra-cotta blocks..... | 30 | walls..... | 57 |
| advantages..... | 41 | Vent pipe..... | 82 |
| backing..... | 43 | | |
| construction..... | 42 | Wainscot..... | 64 |
| Terra-cotta, convention..... | 15 | Walls, covering for frame..... | 54, 55 |
| flue lining..... | 50 | foundation, materials for..... | 35 |
| specifications..... | 78 | masonry..... | 36 |
| kinds..... | 29 | stone..... | 26 |
| Throat, fireplace..... | 51 | terra-cotta tile..... | 43 |
| Timber, sizes of framing..... | 79 | veneered..... | 57 |
| Tin..... | 100 | Waste pipe..... | 82 |
| Tracing cloth..... | 5 | Waterproofing..... | 31, 32 |
| Transom..... | 59 | Water supply..... | 83 |
| Traps..... | 82 | Water table..... | 55 |
| Tread..... | 65 | specifications..... | 80 |
| Trim..... | 63 | Weatherboarding, see Siding. | |
| specifications..... | 80 | Webs..... | 30 |
| Trimmer arch..... | 51 | Winders..... | 65 |
| specifications..... | 78 | Windows, design of..... | 71 |
| Trimmers..... | 46 | estimating..... | 98 |
| specifications..... | 79 | frames for, specifications..... | 80 |
| Truss, over openings..... | 49 | kinds..... | 59 |
| structural principle..... | 74 | openings, framing (See Fenestration.)..... | 48 |
| Unit of accommodation..... | 89 | Wiring..... | 84 |
| Unity..... | 20 | estimating..... | 100 |
| Utility..... | 69 | Wood, conventions for..... | 15 |

THE WILEY TECHNICAL SERIES

EDITED BY J. M. JAMESON

Carefully adapted texts which cover the various divisions of Electricity; Electrical Power and Machinery; Applied Mechanics; Household and Agricultural Chemistry; Drafting and Design; Steam and Gas Power; Shop Practice; Applied Mathematics; Agriculture; Household Economics, etc.

The following texts are announced; others are being added rapidly:

ELECTRICITY

The Essentials of Electricity: A Textbook for Wiremen and the Electrical Trades. By W. H. Timbie, Wentworth Institute. 12mo, flexible covers, pocket size, xiii + 271 pages, 224 figures. Cloth, \$1.25 net.

The Elements of Electricity: For Technical Students. By W. H. Timbie, Head of Department of Applied Science, Wentworth Institute. Small 8vo, xi + 556 pages, 415 figures. Cloth, \$2.00 net.

Direct and Alternating Current Machinery. By Professor J. H. Morecroft, Columbia University. (*Ready in Fall, 1913.*)

Alternating Currents. By W. H. Timbie, Head of Department of Applied Science, Wentworth Institute, and H. H. Higbie, Professor of Electrical Engineering, University of Michigan. (*In preparation.*)

Electric Lighting. By H. H. Higbie, Professor of Electrical Engineering, University of Michigan. (*In preparation.*)

Introduction to Industrial Electricity. By W. H. Timbie, Head of Department of Applied Science, Wentworth Institute. (*In preparation.*)

HEAT AND HEAT ENGINEERING

Heat: A Textbook for Technical and Industrial Students. By J. A. Randall, Instructor in Mechanics and Heat, Pratt Institute. Small 8vo, xiv + 331 pages, 80 figures. Cloth, \$1.50 net.

Gas Power. By Professors C. F. Hirshfeld and T. C. Ulbricht, Cornell University. Small 8vo, viii + 198 pages, 60 figures.

Steam Power. By Professors C. F. Hirshfeld and T. C. Ulbricht, Cornell University. (*In preparation.*)

Heat and Light in the Household. By W. G. Whitman, State Normal School, Salem, Mass. (*In preparation.*)

MECHANICS

Elementary Practical Mechanics. By J. M. Jameson, Vice-President, Girard College; Formerly Head of Department of Physics, Pratt Institute. Small 8vo, xii + 321 pages, 212 figures. Cloth, \$1.50 net.

Mechanics for Machinists. By R. W. Burnham, Erasmus Hall High School, Brooklyn, Instructor in Evening Machine Work, Pratt Institute. (*In preparation.*)

MATHEMATICS

Practical Mathematics. By C. R. Dooley, Westinghouse Electric and Manufacturing Company, Pittsburgh, Pa. (*In preparation.*)

A Shop Mathematics for Machinists. By R. W. Burnham, Instructor in Machine Work, Pratt Institute Evening School. (*In preparation.*)

AGRICULTURE

Poultry. By Professor J. C. Graham, Massachusetts Agricultural College. (*In preparation.*)

Soils. By Professor A. G. McCall, Ohio State University. (*In preparation.*)

Agricultural Chemistry. By Professor T. E. Keitt, Clemson Agricultural College. (*In preparation.*)

Injurious Insects. By Dean E. D. Sanderson and Professor L. M. Peairs, West Virginia University. (*In preparation.*)

Agricultural Drafting. By Charles B. Howe, M.E. 4to, x + 63 pages, 45 figures, 26 plates. \$1.25 net.

FIELD MANUALS IN AGRICULTURE

A carefully selected series of laboratory and field studies, with supplementary theory and information for classroom use. 4to, loose leaf or bound in paper covers.

Studies of Trees: Their Diseases and Care. By J. J. Levison, M.F., Lecturer on Ornamental and Shade Trees, Yale University Forest School, Forester to the Department of Parks, Brooklyn, N. Y.

Exercises in Farm Dairying. By Professor C. Larsen, Department of Dairy Husbandry, South Dakota State College. Single exercises, 2 cents each. Complete, \$1.00 net.

Exercises in Poultry Raising. By Professor J. C. Graham, Massachusetts Agricultural College. (*In preparation.*)

Studies of Insects. By Dean E. D. Sanderson, and Professor L. M. Peairs, West Virginia Agricultural College. (*In preparation.*)

Market Gardening. By Professor F. L. Yeaw, Oasis Farm & Orchard Company, Roswell, New Mexico; formerly Professor of Market Gardening, Massachusetts Agricultural College. (*In preparation.*)

Farm Crops and Soils. By Professor A. G. McCall, Department of Agronomy, Ohio State University. (*In preparation.*)

Exercises in Agricultural Chemistry. By Professor T. E. Keitt, Clemson Agricultural College. (*In preparation.*)

THE LOOSE LEAF LABORATORY MANUAL

A series of carefully selected exercises to accompany the texts of the series, covering every subject in which laboratory or field work may be given. Each exercise is complete in itself, and is printed separately. These will be sold by the single sheet as selected or complete, bound in paper cover.

Exercises in General Chemistry. By Charles M. Allen, Head of Department of Chemistry, Pratt Institute. An introductory course in Applied Chemistry, covering a year's laboratory work on the acid-forming and metallic elements and compounds, 4to, 62 pages, 61 exercises.

Selected exercises, as desired, to fit an ordinary binder, two cents each. Complete in paper cover, \$1.00 net.

Exercises for the Applied Mechanics Laboratory. By J. P. Kottcamp, M.E., Instructor in Steam and Strength of Materials, Pratt Institute. Steam, Strength of Materials, Gas Engines, and Hydraulics. 4to, 60 exercises, with numerous cuts and tables.

Selected exercises as desired, to fit an ordinary binder, two cents each. Complete in paper cover, \$1.00 net.

Wiring Exercises. By H. A. Calderwood, Carnegie Institute of Technology. (*In preparation.*)

Quantitative Chemical Analysis. By Charles M. Allen, Head of Department of Chemistry, Pratt Institute. 4to. Single pamphlets, ten cents each. Complete in paper cover, \$1.00 net.

Exercises in Industrial Chemistry. By Dr. Allen Rogers, Instructor in Industrial Chemistry, Pratt Institute. (*In preparation.*)

Technical Chemical Analysis. By R. H. H. Aungst, Instructor in Technical Chemistry, Pratt Institute. Complete in paper cover, 85 cents net. Single pamphlets furnished as desired.

Qualitative Chemical Analysis. By C. E. Bivins, Instructor in Qualitative Analysis, Pratt Institute. (*Ready Fall, 1913.*)

Elementary Electrical Testing. By Prof. V. Karapetoff, Cornell University. Twenty-five direction sheets with numerous diagrams and cuts. Single sheets, two cents each. Complete in paper cover, 50 cents net.

Exercises in Mechanics. By J. M. Jameson, Vice-President, Girard College; formerly Head of Department of Physics, Pratt Institute. Fifty-two exercises with numerous cuts. Single exercises, two cents each. Complete in paper cover, 85 cents net.

Exercises in Heat. By J. A. Randall, Instructor in Mechanics and Heat, Pratt Institute. (*Ready Fall, 1913.*)

Electrical Measurements. A.C. and D.C. By W. H. Timbie, Head of Department of Applied Science, Wentworth Institute. Forty-nine exercises with numerous diagrams and cuts. Single exercises, two cents. Complete in paper covers, 85 cents net.

SHOP TEXTS

Machine Shop Practice. By W. J. Kaup, Westinghouse Electric and Manufacturing Company, Pittsburgh, Pa. Small 8vo, ix + 227 pages, 186 figures. Cloth, \$1.25 net.

Pattern Making. By Frederick W. Turner and Daniel G. Town, Mechanic Arts High School, Boston. (*In preparation.*)

Tool Making. By W. J. Kaup, Westinghouse Electric and Manufacturing Company, and J. A. Chamberlain, Supervisor of Manual Training, Washington, D. C. (*In preparation.*)

A Shop Mathematics for Machinists. By R. W. Burnham, Instructor in Machine Work, Pratt Institute Evening School. (*In preparation.*)

DRAFTING AND DESIGN

Agricultural Drafting. By Charles B. Howe, M.E. 4to, x + 63 pages, 45 figures, 26 plates. \$1.25 net.

Loose Leaf Manual in Agricultural Drafting. By Charles B. Howe, M. E. Forty problem sheets to supplement the preceding text. Price, two cents each.

Architectural Drafting. By A. Benton Greenberg, B. A. Formerly Inspector and Draftsman, Supervising Architect's Office, Washington, D. C., Engineer and Inspector, Building Department, New York City, Practising Architect. In Collaboration with Charles B. Howe, M. E. 4to, viii + 110 pages, 53 figures, 10 plates. \$1.50 net.

THE LOOSE LEAF DRAFTING MANUAL

Reference and Problem Sheets to accompany the texts in Drafting and Design. These will be furnished singly as selected, and are designed to enable the instructor to adapt his instruction closely to the needs of his class. (*In preparation.*)

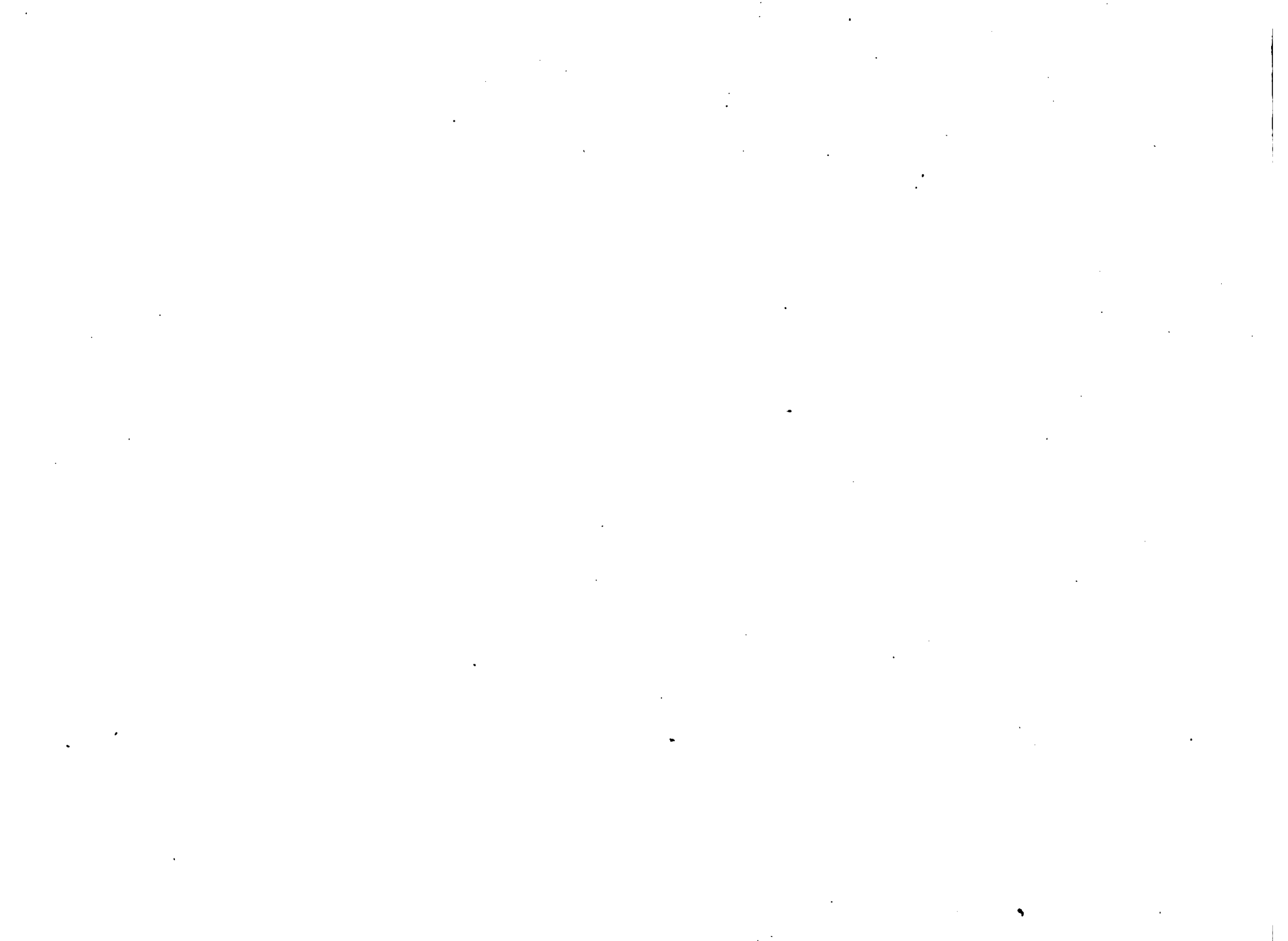

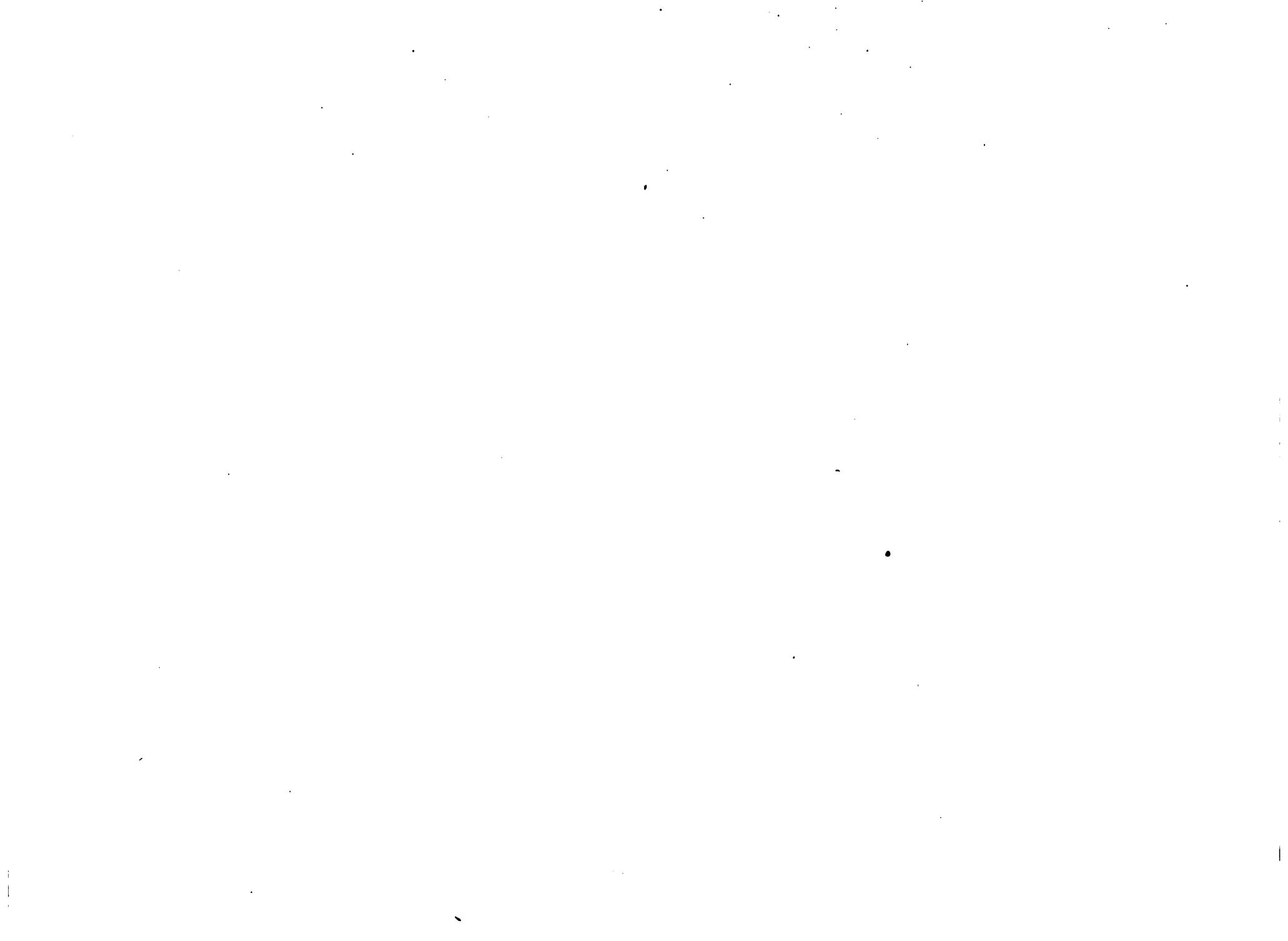

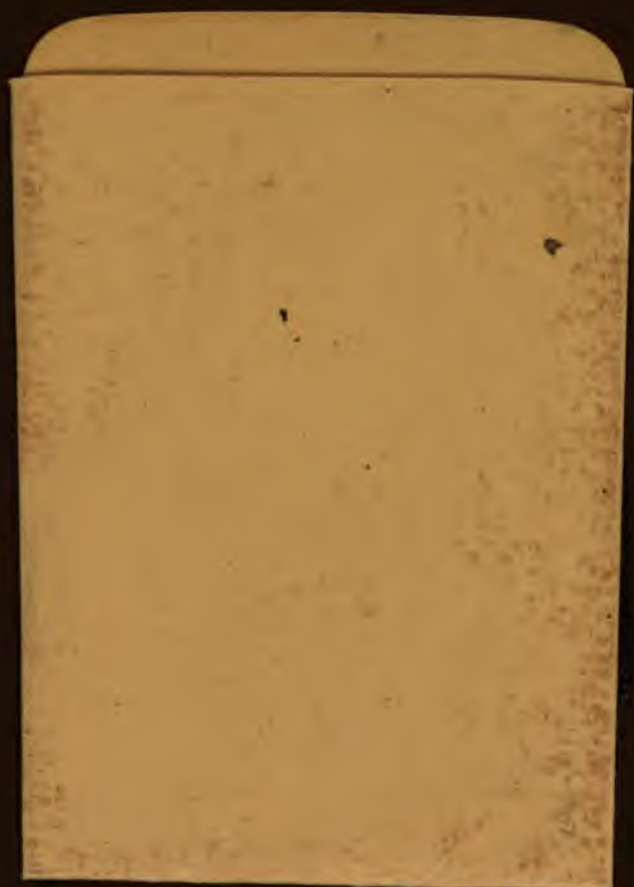

89087404653



B89087404653A